



US Army Corps
of Engineers®

PHASE II MAIN REPORT

TURBINE OPTIMIZATION FOR PASSAGE OF JUVENILE SALMON AT HYDROPOWER PROJECTS ON THE COLUMBIA AND LOWER SNAKE RIVERS



PREPARED BY
U.S. ARMY CORPS OF ENGINEERS
TURBINE SURVIVAL PROGRAM

NOVEMBER 2013

REVISION 0

EXECUTIVE SUMMARY

This Phase II Turbine Survival Program (TSP) Report provides discussion regarding the best turbine operating conditions for juvenile salmonids passing through turbines of U.S. Army Corps of Engineers (USACE) hydropower projects on the lower Columbia and Snake rivers. This report also provides recommended guidelines for the operation of turbines at specific projects where adequate data is available. The eight USACE hydropower projects being studied by the TSP include Bonneville (first and second powerhouses) The Dalles, John Day and McNary on the lower Columbia River and Ice Harbor, Lower Monumental, Little Goose and Lower Granite on the lower Snake River. The 2004 TSP Phase I report identified turbine passage conditions that may improve juvenile fish survival, and suggested that the best target operating range (TOR) may not coincide with peak efficiency as previously assumed, but may better correlate to “open turbine geometry.” The TSP Phase I report recommended conducting further research to better define the optimum TOR for the eight hydropower projects.

This Phase II report, which addresses the Phase I recommendations, is considered a “working document” as it includes results from studies conducted to date and provides place holders for future project-specific research and analysis. It is recognized that many of the USACE hydropower projects are similar in design and turbine type. Where possible, the TSP has applied study results from one or more specific projects to similar type projects with less available data.

As estimated through biological field studies, the survival of juvenile fish passing through turbines is generally represented by one of two measures: direct survival and total turbine passage survival. Direct survival is typically measured using Hi-Z balloon-tag methods and represents the survival of fish having experienced the most direct effects of turbine passage, mainly the risk of exposure to direct blade strike, hydraulic shear forces, and/or pressure-related injury (barotrauma). Total turbine passage survival is typically measured using telemetry methods relying on use of either radio telemetry tags or acoustic telemetry tags. Total turbine passage survival represents the survival of run-of-the river fish having experienced the complete turbine passage, as well as delayed effects and/or post turbine passage exposures. An example of these delayed or indirect effects is the increased risk of predation resulting from sub-lethal injuries and/or disorientation caused by the turbine passage.

Phase II of the TSP has focused study efforts on identifying turbine and project operations that minimize both direct and indirect causes of turbine mortality. A number of studies including field studies, laboratory studies, physical hydraulic model studies, and numerical model evaluations have been conducted throughout both Phase I and Phase II to provide a basis for turbine optimization. It has become increasingly more apparent that delayed and/or indirect effects of turbine passage can be as significant, if not more significant, than the direct effects. The full benefits of turbine optimization may not be realized unless the turbine egress conditions are also optimized.

The primary causes of direct mortality are strike and impact forces, hydraulic and mechanical shear forces, and extreme pressure changes. In general, the strike/impact and shear forces can be minimized by operating the turbine units in an open geometry, where the wicket gates are well aligned with the stay vanes and the runner blades are at a steep angle. This generally occurs at unit discharges above the peak efficiency point and near or beyond the upper 1% operating limit. The higher flows tend to reduce turbulence and provide for improved draft tube conditions. Turbine pressures, however, tend to become more extreme as turbine flows increase due to the increase in velocity. Turbine unit optimization for fish passage must weigh the benefits of reducing exposure to strike and shear forces against the increase risk of pressure-related injuries (i.e., barotraumas). Although the risk or mortality from barotraumas is very

difficult to quantify, the benefits of reducing direct injuries through open geometry are expected to outweigh the risk of barotraumas for most of the USACE hydropower projects on the Snake and Columbia rivers. Based on analysis of past direct tag studies (Hi-Z balloon tag) and the physical hydraulic model studies, it is not unreasonable to expect an approximate 2% increase in direct turbine survival. Without a thorough biological test of turbine operations, it is not reasonable to assume or estimate the increase in “total” turbine passage survival as a result of open geometry operations.

In addition to reducing risk of direct impact and strike, the open geometry operation tends to improve the draft-tube conditions by reducing turbulence and improves egress when multiple turbines are operated adjacent one and another. The open geometry is defined for specific turbine unit families in the 2010 Hydroelectric Design Center report, *Columbia and Snake River Turbines Stay Vane and Wicket Gate Geometry Study*, as well as in further detail in this report.

The TSP also recommends additional research and analysis. A pressure effects risk assessment is necessary to more accurately weigh the risk of pressure related mortality against the benefits of reduce strike/impact when operating in an open geometry. To complete this assessment, additional prototype turbine pressure data is needed and the depth distribution of acclimated fish prior to turbine passage must be well defined.

Based on the available information, the TSP recommends a TOR for improved fish passage for most of the hydropower projects. The TSP plans to update and add to the TORs by updating this document as new information becomes available. As indicated above, turbine passage egress is an important component; thus, the TSP also provides recommendations on target project operations to improve total turbine passage survival. In addition, turbine survival tests should be conducted to verify the TSP-defined TORs and target project operations.

The conclusions in this report are based on current information. The report will be revised as new information becomes available that may change the identified TORs. The recommended TORs are based on maximizing turbine passage survival and not all project considerations were fully evaluated. The regional stakeholders would need to look at the project holistically prior to adoption of these recommendations.

TABLE OF CONTENTS

EXECUTIVE SUMMARY

ACRONYMS AND ABBREVIATIONS

1.	INTRODUCTION	1
1.1.	TURBINE SURVIVAL TESTING	1
1.2.	DESCRIPTION OF THE PROJECTS	2
1.2.1.	Bonneville Lock and Dam	3
1.2.2.	The Dalles Lock and Dam	4
1.2.3.	John Day Lock and Dam.....	5
1.2.4.	McNary Lock and Dam.....	7
1.2.5.	Ice Harbor Lock and Dam.....	8
1.2.6.	Lower Monumental Lock and Dam	9
1.2.7.	Little Goose Lock and Dam.....	10
1.2.8.	Lower Granite Lock and Dam	11
2.	FACTORS IN MORTALITY OF TURBINE-PASSED FISH.....	15
3.	DEFINE TARGET OPERATING RANGE FOR TURBINES	19
3.1.	INTRODUCTION.....	19
3.2.	PHYSICAL GEOMETRY CONSIDERATIONS	19
3.3.	PHYSICAL OBSERVATIONAL MODEL INFORMATION.....	22
3.3.1.	Overview	22
3.3.2.	Bonneville Dam	22
3.3.3.	The Dalles Dam	24
3.3.4.	John Day Dam.....	24
3.3.5.	McNary Dam	24
3.3.6.	Ice Harbor Dam.....	25
3.3.7.	Lower Monumental Dam	26
3.3.8.	Little Goose Dam	26
3.3.9.	Lower Granite Dam	26
3.4.	PRESSURE INFORMATION FROM LABORATORY AND FIELD DATA.....	27
3.4.1.	Overview	27
3.4.2.	Bonneville Dam	29
3.4.3.	The Dalles Dam	31
3.4.4.	John Day Dam.....	31
3.4.5.	McNary Dam	31
3.4.6.	Ice Harbor Dam.....	32
3.4.7.	Lower Monumental Dam	32
3.4.8.	Little Goose Dam	33
3.4.9.	Lower Granite Dam	33
3.5.	BIOLOGICAL FIELD STUDY INFORMATION.....	33
3.5.1.	Overview	33
3.5.2.	Bonneville Dam	33
3.5.3.	There are no known studies for turbine passage survival at different operating conditions for B2; however; route-specific survival estimates are available from 2010 and 2011 performance standard testing. Although no specific turbine operations were tested, Ploskey et al. (2012) estimated yearling Chinook turbine passage survival ($\pm 95\%$ confidence) through B2 at 95.7% (93.9 – 97.5) in 2010 and 94.7% (90.2 – 99.2) in 2011. Juvenile steelhead turbine passage survival was estimated ($\pm 95\%$ confidence) to be slightly lower compared to yearling Chinook at 91.1% (86.6 – 95.6) in 2010 and 91.1% (85.4 – 97.6) in 2011 (Ploskey et al. 2012). The Dalles Dam.....	34

3.5.4. There are no known studies for turbine passage survival at different operating conditions; however, route-specific survival estimates are available from 2010 and 2011 performance standard testing. Although no specific turbine operations were tested, Ploskey et al. (2012) estimated yearling Chinook turbine passage survival ($\pm 95\%$ confidence) through The Dalles at 87.6% (80.6 – 94.6) in 2010 and 93.0% (90.7 – 95.3) in 2011. Juvenile steelhead turbine passage survival was estimated ($\pm 95\%$ confidence) to be slightly lower compared to yearling Chinook at 88.8% (82.2 – 95.4) in 2010 and 91.9% (88.7 – 95.1) in 2011 (Ploskey et al. 2012).

3.5.4.	John Day Dam	34
3.5.5.	McNary Dam	34
3.5.6.	Ice Harbor Dam.....	35
3.5.7.	Lower Monumental Dam	36
3.5.8.	Little Goose Dam	36
3.5.9.	Lower Granite Dam	36
3.6.	TARGET OPERATING RANGE DATA SUMMARY	37
3.6.1.	Bonneville Dam	37
3.6.2.	The Dalles Dam	38
3.6.3.	John Day Dam.....	38
3.6.4.	McNary Dam	39
3.6.5.	Ice Harbor Dam.....	40
3.6.6.	Lower Monumental Dam	41
3.6.7.	Little Goose Dam	41
3.6.8.	Lower Granite Dam	41
4.	DEFINE TARGET PROJECT OPERATIONS	43
4.1.	BONNEVILLE DAM	43
4.2.	THE DALLES DAM.....	43
4.3.	JOHN DAY DAM.....	43
4.4.	M McNARY DAM	44
4.5.	ICE HARBOR DAM	44
4.6.	LOWER MONUMENTAL DAM	44
4.7.	LITTLE GOOSE DAM.....	45
4.8.	LOWER GRANITE DAM.....	45
5.	OTHER CONSIDERATIONS.....	47
5.1.	BONNEVILLE DAM	47
5.1.1.	First Powerhouse (B1)	47
5.1.2.	Second Powerhouse (B2).....	47
5.2.	THE DALLES DAM.....	47
5.3.	JOHN DAY DAM.....	47
5.4.	M McNARY DAM	47
5.5.	ICE HARBOR DAM	48
5.6.	LOWER MONUMENTAL DAM	49
5.7.	LITTLE GOOSE DAM.....	49
5.8.	LOWER GRANITE DAM.....	49
6.	RECOMMENDED PATH FORWARD.....	51
6.1.	BONNEVILLE DAM	51
6.1.1.	First Powerhouse (B1)	51
6.1.2.	Second Powerhouse (B2).....	52
6.2.	THE DALLES DAM.....	52
6.3.	JOHN DAY DAM.....	52
6.4.	M McNARY DAM	53
6.5.	ICE HARBOR DAM.....	54
6.6.	LOWER MONUMENTAL DAM	55

6.7. LITTLE GOOSE DAM..... 55
6.8. LOWER GRANITE DAM..... 55
7. REFERENCES 57

LIST OF TABLES

Table 1. Corps of Engineers Families of Turbines 13
Table 2. Fish Injury when Exposed to Shear Strain..... 16
Table 3. Approximate Best Wicket Gate Geometry 20
Table 4. Best Wicket Gate Geometry Operating Ranges..... 21
Table 5. Calculated Barotrauma Mortality for B1 Turbines..... 29
Table 6. Bonneville Turbine Unit 16 Nadir Pressures and Calculated Mortality 30
Table 7. John Day Nadir Pressures and Calculated Mortality 31
Table 8. Ice Harbor Nadir Pressures and Calculated Mortality 32
Table 9. McNary Gatewell Fish Condition at Different Operating Conditions 48

LIST OF FIGURES

Figure 1. Columbia and Snake River Projects 1
Figure 2. Bonneville First Powerhouse and Bradford Island Fish Ladder..... 3
Figure 3. Bonneville Second Powerhouse and North Fish Ladder 4
Figure 4. Diagram of The Dalles Lock and Dam..... 5
Figure 5. John Day Powerhouse, South Fish Ladder, and Juvenile Fish Bypass System..... 6
Figure 6. John Day Dam Spillway, Navigation Lock, and North Fish Ladder 7
Figure 7. Diagram of McNary Lock and Dam..... 8
Figure 8. Diagram of Ice Harbor Lock and Dam 9
Figure 9. Diagram of Lower Monumental Lock and Dam 10
Figure 10. Diagram of Little Goose Lock and Dam 11
Figure 11. Diagram of Lower Granite Lock and Dam..... 12
Figure 12. Passage of Neutrally Buoyant Bead through Physical Turbine Model 15
Figure 13. Example of Pressure Exposure during Turbine Passage 17
Figure 14. Percentage of Juvenile Rainbow Trout Injured when Exposed to Headfirst Jet with Predation Challenge Performed at Two Different Jet Exposures..... 18
Figure 15. Decompression Mortality for Tagged Juvenile Chinook (Carlson et al. 2010)..... 28
Figure 16. Decompression Mortality for In-river Juvenile Chinook (Carlson et al. 2010)..... 28
Figure 17. B2 Nadir Pressure Probability Distribution based on sensor fish data 30
Figure 18. Combined Information on Direct Turbine Mortality for B1 Turbines 38
Figure 19. Combined Information for Turbine Mortality at John Day 39
Figure 20. Combined Information for Turbine Mortality at McNary 40
Figure 21. Proposed Target Operating Range at 55 feet of Head for B1 Turbines..... 51
Figure 22. Proposed Target Operating Range at 100 ft of Head for John Day Turbines..... 48
Figure 23. McNary Turbines Proposed Target Operating Range at 75 Feet of Head..... 49

APPENDICES

- Turbine Optimization for Passage of Juvenile Salmon at Bonneville Dam First Powerhouse
- Turbine Optimization for Passage of Juvenile Salmon at John Day Dam
- Turbine Optimization for Passage of Juvenile Salmon at McNary Dam
- Turbine Optimization for Passage of Juvenile Salmon at Lower Monumental Dam
- Comprehensive Turbine Survival Testing Considerations

ACRONYMS AND ABBREVIATIONS

AC	Allis-Chalmers (turbine manufacturer)
B1	Bonneville First Powerhouse
B2	Bonneville Second Powerhouse
BiOp	Biological Opinion
BLH	Baldwin-Lima-Hamilton (turbine manufacturer)
BIT	biological index testing
CFD	computational fluid dynamics
cfs	cubic feet per second
CI	confidence interval
cm	centimeter(s)
CRFM	Columbia River Fish Mitigation
ERDC	Engineering Research and Development Center
ESBS	extended submersible barrier screens
FPP	Fish Passage Plan
HDC	Hydroelectric Design Center
JBS	juvenile bypass system
kcf/s	thousand cubic feet per second
ft/s	feet (foot) per second
LDV	Laser Doppler Velocimeter
LRP	log ratio of pressures
MABL	Mobile Aquatic Barotrauma Laboratory
MGR	minimum gap runner
MW	megawatt(s)
NOAA	National Oceanic and Atmospheric Administration
PNNL	Pacific Northwest National Laboratory
psia	pounds per square inch absolute
SE	standard error
STS	submersible traveling screens
TOR	target operating range
TSP	Turbine Survival Program
TST	turbine survival testing
USACE	U.S. Army Corps of Engineers
VBS	vertical barrier screen

1. INTRODUCTION

The Turbine Survival Program (TSP) is part of the U.S. Army Corps of Engineers' (USACE) multi-faceted Columbia River Fish Mitigation (CRFM) program. The TSP was developed to evaluate juvenile fish passage through turbines at the eight USACE hydropower projects on the Columbia and lower Snake rivers, with an emphasis on identifying turbine features and conditions that cause injury to fish. These eight projects are Bonneville, The Dalles, John Day, McNary, Ice Harbor, Lower Monumental, Little Goose, and Lower Granite (Figure 1). These projects are required to have both upstream and downstream fish passage.

Figure 1. Columbia and Snake River Projects

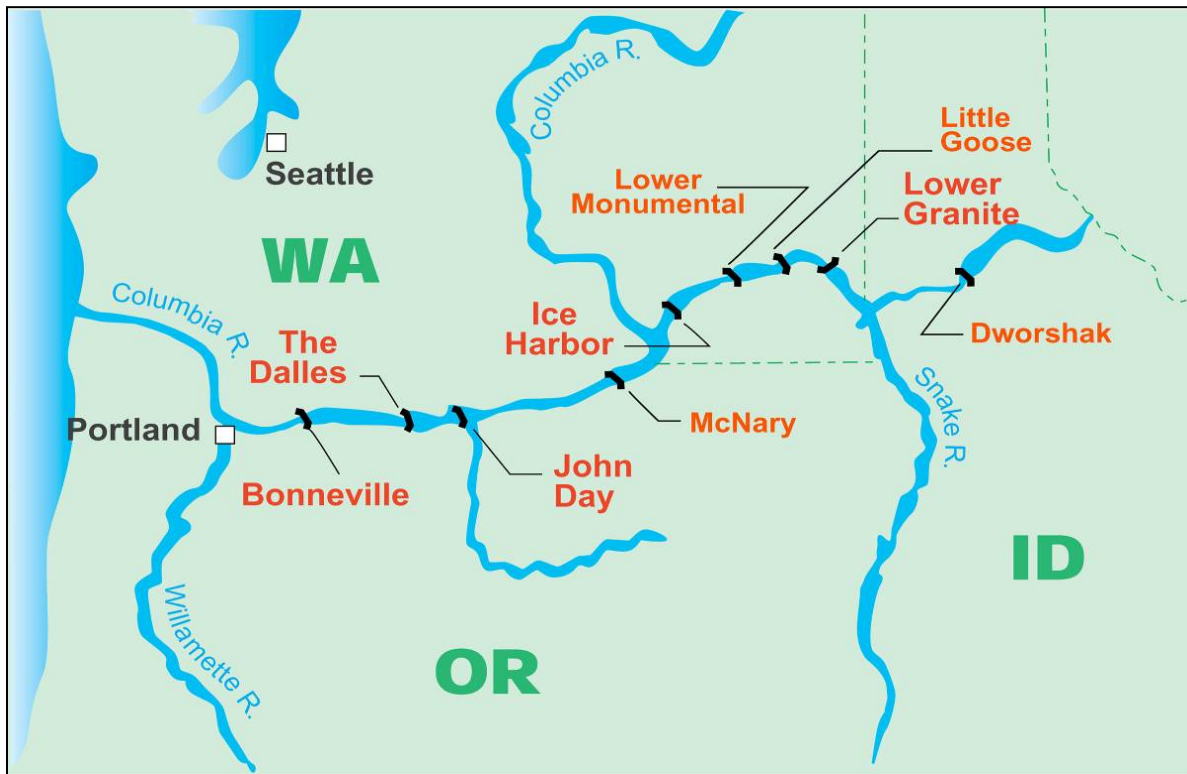

The first phase of the TSP involved developing tools to evaluate the physical conditions fish experience as they pass through the large Kaplan turbines typical of USACE projects on the lower Columbia and Snake rivers. This effort is summarized in the TSP Phase I Report (USACE 2004). In support of the National Oceanic and Atmospheric Administration (NOAA) Fisheries Biological Opinions (BiOps; NOAA 2000, 2004, 2008), the TSP recommends biological index testing (BIT) as a continued Phase II effort. In this report, BIT will be referred to as turbine survival testing (TST).

1.1. TURBINE SURVIVAL TESTING

Survival estimates of juvenile fish passing through turbines generally represent one of two measures: direct survival or total turbine passage survival. Direct survival is typically measured using Hi-Z balloon-tag methods and represents the survival of fish having experienced the most direct effects of turbine

passage, mainly the risk of exposure to direct blade strike and extreme mechanical and hydraulic shear forces. Total turbine passage survival is typically measured using telemetry methods relying on use of either radio or acoustic telemetry tags. Total turbine passage survival represents the survival of run-of-the river fish having experienced the complete turbine passage, as well as delayed and/or indirect effects post turbine passage. An example of these delayed or indirect effects is the increased risk of predation resulting from sub-lethal injuries and/or disorientation caused by the turbine passage. The rate of indirect mortality caused by predation can be exacerbated by poor egress conditions from the immediate powerhouse tailrace region. Stagnant or circulating flow patterns caused by the manner in which the spillway and powerhouse are operated can subject juvenile fish to large areas where predatory fish may hold. Stunned or disoriented fish may also rise to the surface where they may be more susceptible to avian predation.

The goal of this Phase II report is to identify turbine operations that optimize the total turbine passage survival by minimizing causes of both direct and indirect mortality of all fish passing through the turbines. The first step in this process is to identify how to operate an individual turbine unit for the best direct turbine survival and best delivery of fish into the tailrace. The TSP team has identified this as the target operating range (TOR). Identifying the TOR involves a number of tools and is discussed in Section 3 of this report.

The second step is an assessment of tailrace conditions given existing powerhouse and spill operations. Operating turbine units at the TOR should improve the draft tube exit conditions for fish entering the tailrace as well as result in less fish injury. However, tailrace conditions are heavily affected by how the overall project is operated. Therefore, this step investigates ways to operate the project for better tailrace conditions in order to improve indirect survival of fish passing turbines.

The third step is a biological field test of turbine and powerhouse operation plans using live juvenile salmonids as test fish. Because of the high cost of biological tests at prototype scales, data from other biological tests are used as much as possible. While this process can provide some additional information, it will not likely provide conclusive evidence. Therefore, the strategy is to use targeted field studies to test specific hypotheses about turbine operations and configurations developed in previous steps that minimize harm to juvenile salmon. If hypotheses tests provide biologically acceptable results, this will validate proposed turbine configuration and operating recommendations.

1.2. DESCRIPTION OF THE PROJECTS

For each USACE hydropower project on the Columbia and lower Snake rivers, a description of the turbine units and a summary of fishery operations is provided in the following sections. Table 1 provides a summary of data (e.g. runner diameter, number of blades, manufacturer, RPM, etc.) by family of turbine and project. Additional information for each project can be found in the project's appendix to this report.

While configuration varies among projects it should be noted that each turbine unit intake is fitted with a fish guidance screen with the exception of Bonneville Powerhouse I. Fish guidance screens typically extend below the intake ceiling to screen out 1/3 to 2/3 of the turbine intake. Fish that encounter the screen in the upper portion of the turbine intake are typically guided into the gatewell and subsequently into the bypass system. Fish that are unguided pass below the intake screens and subsequently pass through the turbine units.

1.2.1. Bonneville Lock and Dam

Bonneville Lock and Dam is located 146 river miles from the mouth of the Columbia River and about 40 miles east of Portland, Oregon (see Figure 1). Bonneville’s first powerhouse, spillway and original navigation lock were completed in 1938 (Figure 2). A second powerhouse was completed in 1981 (Figure 3), and a larger navigation lock was completed in 1993. The first powerhouse (B1) is 1,027 feet long and contains 10 Voith Hydro Kaplan turbines that were recently rehabilitated (2000-2009) with a total generating capacity of 680 megawatts (MW). The second powerhouse (B2) is 988 feet long and contains eight Allis-Chalmers (AC) Kaplan turbines with a total generating capacity of 558 MW. The B1 turbines are minimum gap runners (MGR) installed from 1998 to 2010 to replace the original runners for the powerhouse. It should be noted that the turbine intake extensions depicted in Figure 3 were installed to improve FGE; however, they provided only marginal benefit and are no longer in use.

At B2, fish by-pass screens are installed in each of the turbine unit intakes. There are no fish by-pass screens at B1. While the screens are effective in intercepting juvenile steelhead, a significant number of juvenile fish pass through the turbines. Turbines are operated within 1% of the best efficiency in accordance with the current USACE Fish Passage Plan (FPP). The FPP also specifies powerhouse priority and unit priority at each powerhouse to maximize adult and juvenile fish movement. Spill is required from April 10 to August 31 each year for juvenile egress. Additional details of the operational requirements at Bonneville can be found in the FPP and in the project’s appendices to this report.

Figure 2. Bonneville First Powerhouse and Bradford Island Fish Ladder

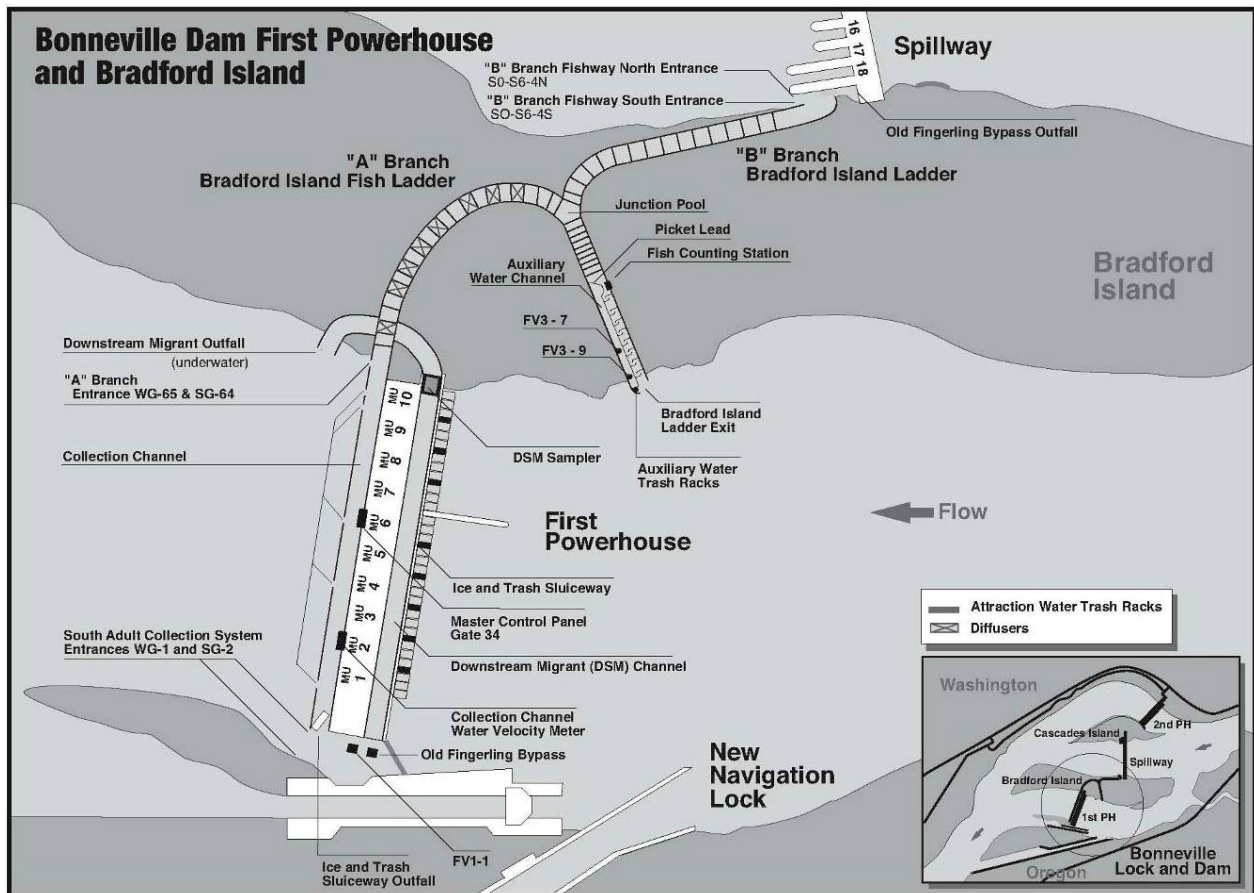
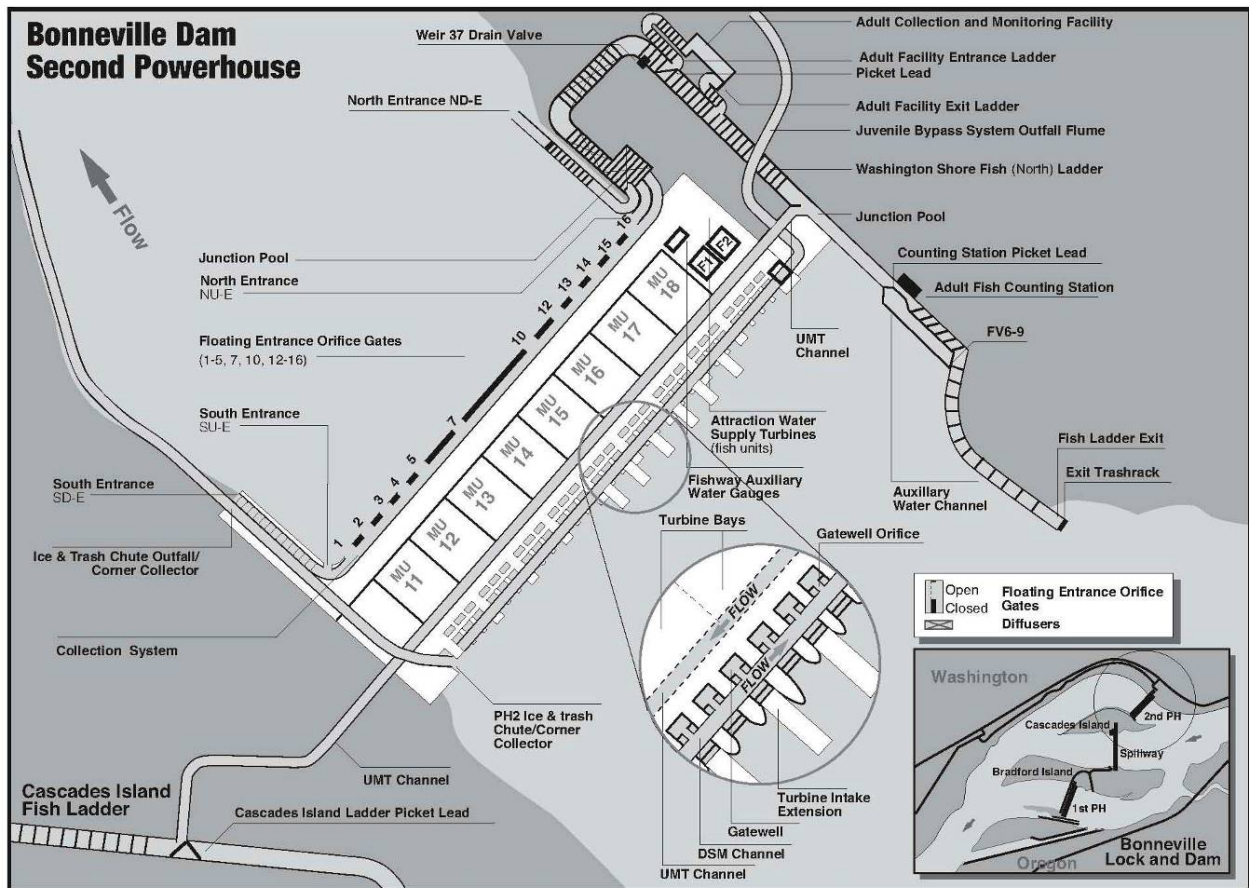

Figure 3. Bonneville Second Powerhouse and North Fish Ladder



1.2.2. The Dalles Lock and Dam

The Dalles Lock and Dam is 192 miles upriver from the mouth of the Columbia River and 2 miles east of the city of The Dalles, Oregon (see Figure 1). Construction of The Dalles started in 1952 and the project began operating 5 years later. The project consists of a navigation lock, spillway, powerhouse, and fish passage facilities (Figure 4). The powerhouse is 2,089 feet long and contains 22 Baldwin-Lima-Hamilton (BLH) Kaplan turbine units with units 1-14 having 280-inch diameter runners and units 15-22 having 300-inch diameter runners for a total generating capacity of 2,100 MW. Units 1-14 were all operating in 1960, while units 15-22 began operating in 1973. Unlike most turbines in the system which turn clockwise, The Dalles turbine units turn counter-clockwise due to the angle of the incoming flow.

The turbine units at The Dalles are not screened. Juvenile fish passage consists of the ice and trash sluiceway and one 6-inch orifice in each gatewell; however, the 6-inch orifices are being closed systematically as time allows. Adult fish passage facilities at The Dalles are composed of a north shore fish ladder, which passes fish collected at the north end of the spillway, and an east fish ladder that passes those fish collected at the south end of the spillway and across the downstream face of the powerhouse. The turbines at The Dalles are operated within 1% of the best efficiency in accordance with the current

FPP. Additional details of the operational requirements at The Dalles can be found in the FPP and in the project's appendix to this report.

Figure 4. Diagram of The Dalles Lock and Dam

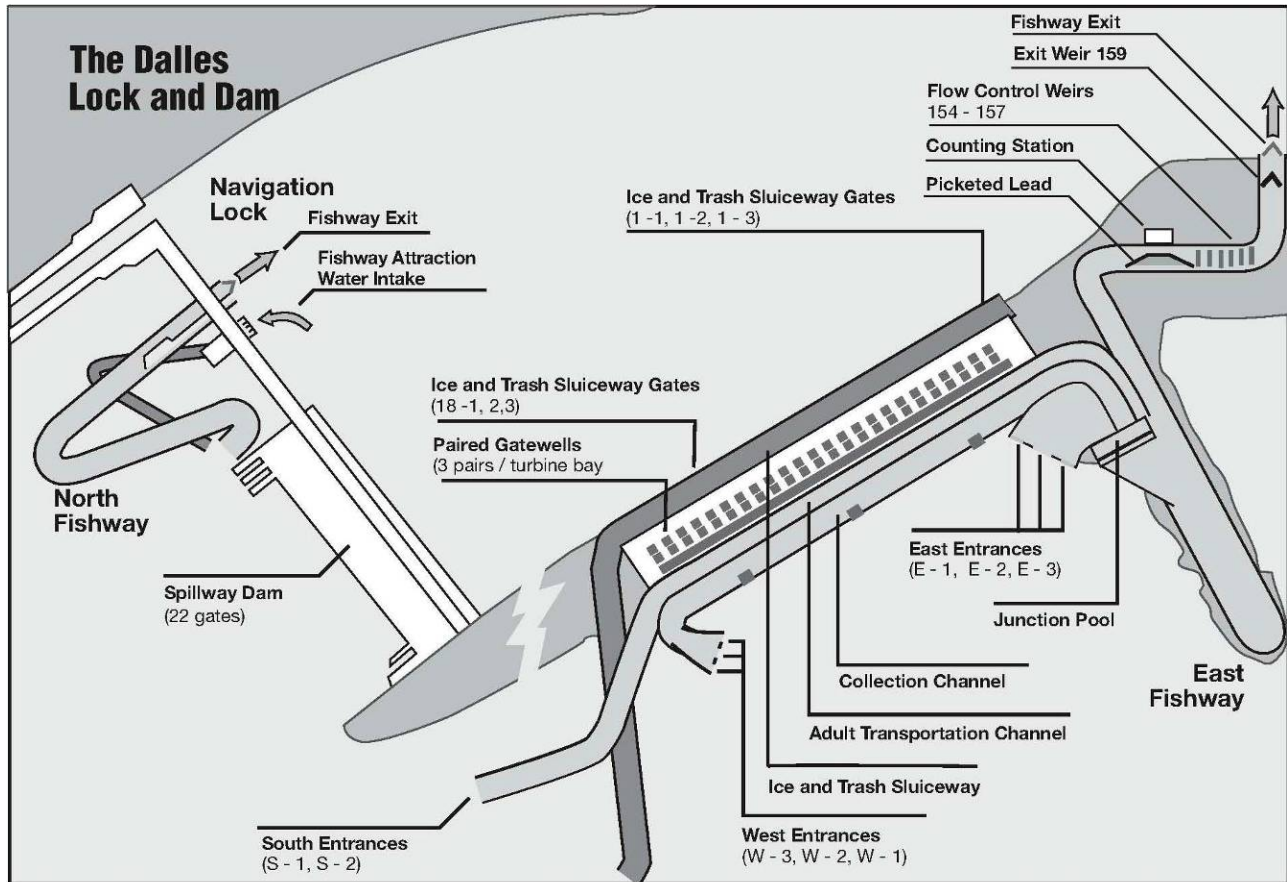

1.2.3. John Day Lock and Dam

John Day Lock and Dam is 216 miles upriver from the mouth of the Columbia River near the city of Rufus, Oregon (see Figure 1). Completed in 1971, the project includes a powerhouse, spillway, navigation lock, and fish passage facilities (Figure 5 and Figure 6). The powerhouse is 1,975-foot long and contains 16 BLH turbines of 155 MW each, for a total generating capacity of 2,480 MW. All turbines are Kaplan, six-blade units operating at 90 revolutions per minute. The last of the 16 generators went on line in November 1971. The north end of the powerhouse has four skeleton bays providing a potential expansion of four additional turbines.

Fish passage facilities include two adult fish ladders and a screened juvenile bypass system (JBS). The north fish ladder has two main entrances located adjacent to spillway bay 1 and exits upstream along the Washington shore. The south fish ladder has three main entrances, one at the south end of the powerhouse and two smaller entrances at its north end. Ten floating orifice-type entrances also are distributed across the downstream powerhouse face. The south fish ladder exits upstream adjacent to the Oregon shore.

The JBS has undergone several modifications in the last 25 years. Currently each main unit intake has a 20-foot submersible traveling screen (STS) that diverts approximately 200 cubic feet per second (cfs) of flow up into a dewatering gate slot. A vertical barrier screen (VBS) located between the dewatering gate slot and the operating gate slot removes all but 14 cfs of this flow. The remaining 14 cfs of water and guided fish are discharged through a 14-inch orifice into a collection channel, and eventually released approximately 600 feet downstream of the powerhouse through an outfall adjacent to the Oregon shore. The JBS also includes a juvenile smolt monitoring facility that was put into operation in 2000.

The John Day turbines are operated within 1% of the best efficiency in accordance with the current FPP. Additional details of the operational requirements at John Day can be found in the FPP and in the project's appendix to this report.

Figure 5. John Day Powerhouse, South Fish Ladder, and Juvenile Fish Bypass System

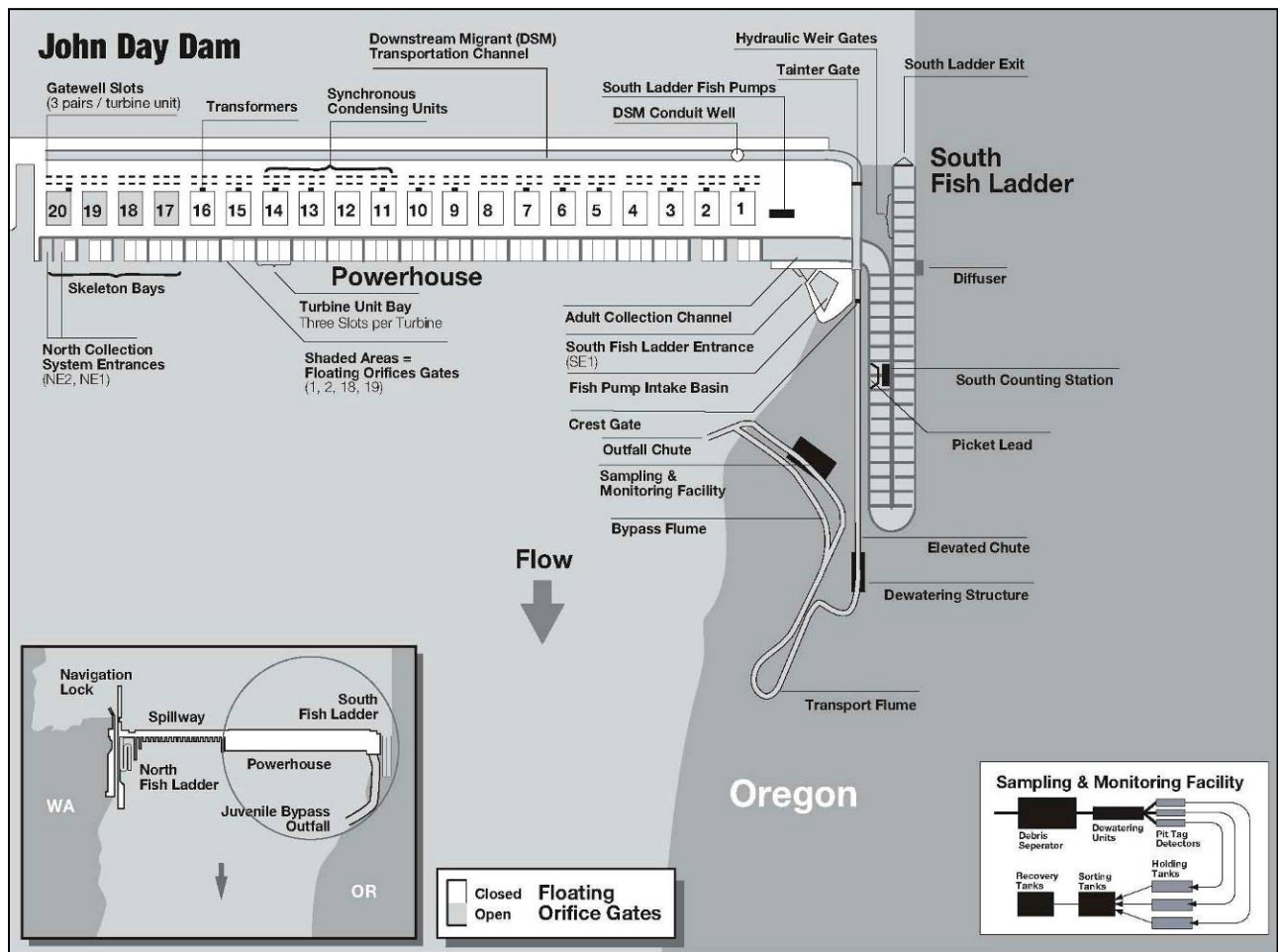
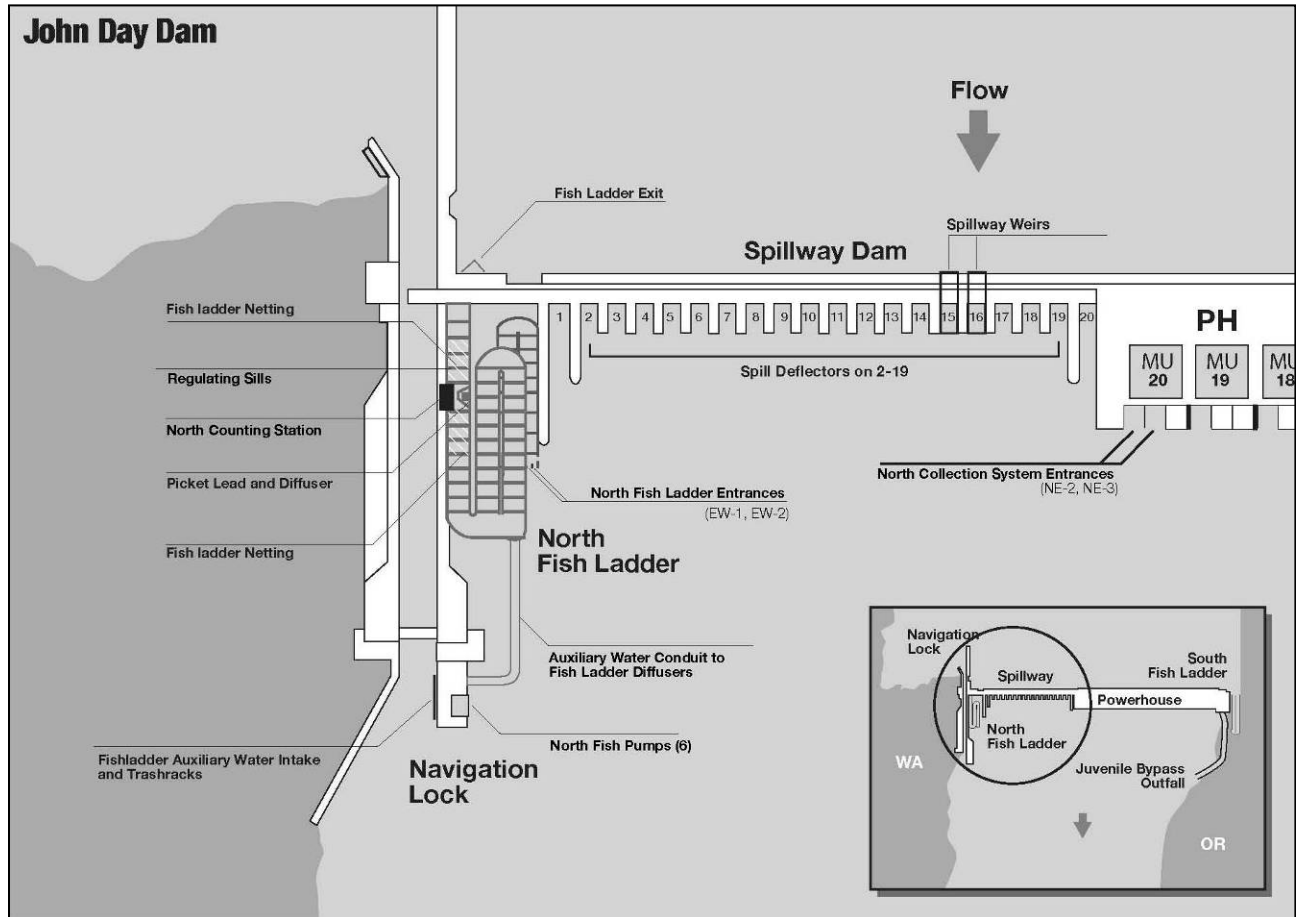

Figure 6. John Day Dam Spillway, Navigation Lock, and North Fish Ladder



1.2.4. McNary Lock and Dam

McNary Lock and Dam is located about 292 miles upstream from the mouth of the Columbia River and 3 miles east of the town of Umatilla, Oregon (see Figure 1). Completed in 1953, the project includes a powerhouse, spillway, navigation lock, and fish passage facilities (Figure 7). The powerhouse is 1,422 feet in length and contains 14 generating units of 84.7 MW each, for a total capacity of 1186 MW. The Kaplan turbine units manufactured by S. Morgan Smith had an original generator capacity of 84.7 MW (USACE 2004), although the majority of generators have been upgraded to 100 MW. The turbine units were put into service in 1954 and the 280-inch diameter runners were designed to operate at 85.7 revolutions per minute.

Extended submersible barrier screens (ESBS) are installed in each of the turbine unit intakes, and at 40 feet in length they screen a significant portion of the intake. The turbines are operated within 1% of the best efficiency in accordance with the current FPP. The FPP also specifies a turbine operating priority from unit 1 and then unit 14 down to unit 2 that is intended to improve adult fish attraction to the fish ladders. The FPP requires spill during much of the fish passage season, which influences the powerhouse tailrace egress conditions. Additional details of the operational requirements at McNary can be found in the FPP and in the project’s appendix to this report.

Figure 7. Diagram of McNary Lock and Dam

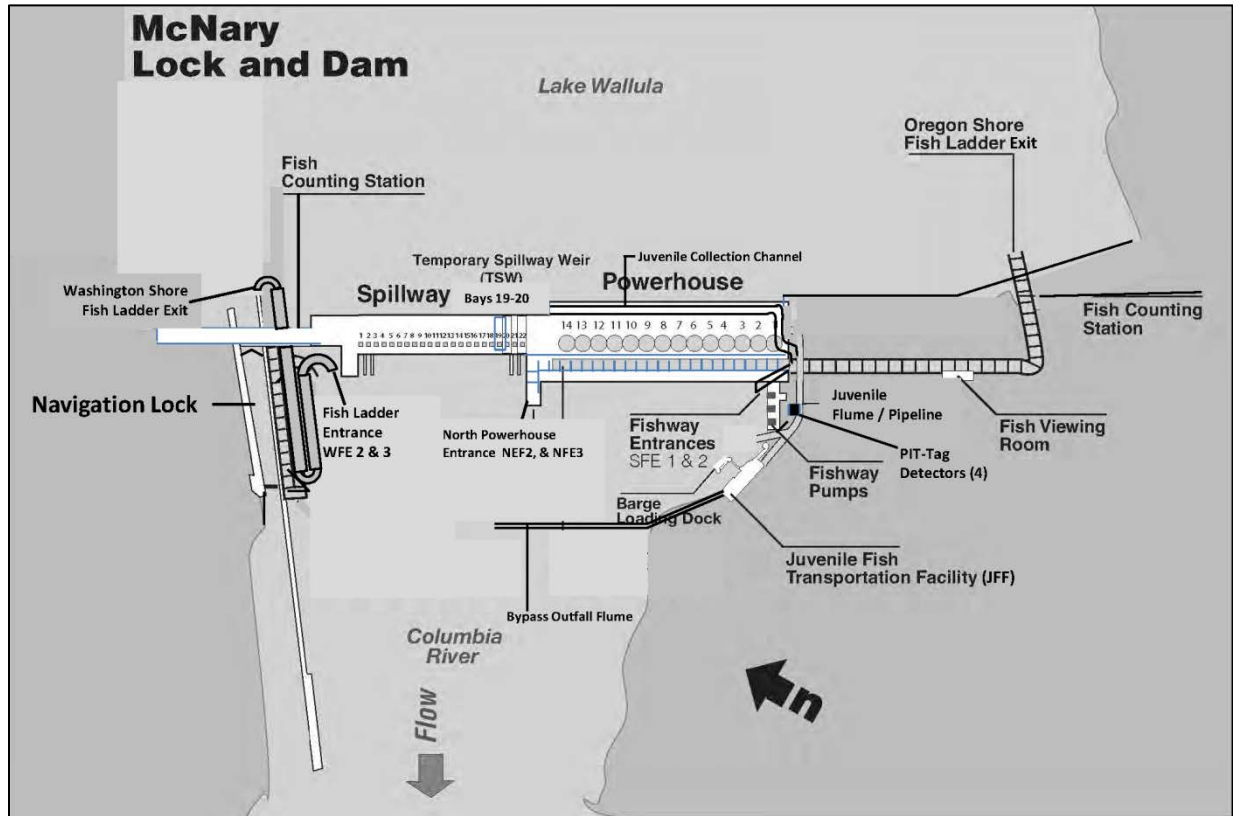

1.2.5. Ice Harbor Lock and Dam

In 1945, Ice Harbor became the first of four dams authorized by Congress for construction on the Snake River. The project is located 9.7 miles upstream from the mouth of the Snake River (see Figure 1). Completed in 1961, the project includes a navigation lock, powerhouse, spillway, fish ladders on each shore, and non-overflow sections (Figure 8). The powerhouse has three 90 MW, 280-inch diameter Kaplan turbines and three 111 MW, 300-inch diameter Kaplan turbines. The six AC turbine units have a total generating capacity of 603 MW. Turbine unit 2 currently operates as a fixed-bladed unit, and plans are underway to replace turbine units 2 (with a new fixed runner) and units 1 and 3 (with a new adjustable runner) at Ice Harbor with units intended to improve fish passage survival.

All six turbines units are screened with submersible traveling screens (STS). The Ice Harbor turbines are operated within 1% of the best efficiency in accordance with the current FPP. Additional details of the operational requirements at Ice Harbor can be found in the FPP and in the project’s appendix to this report.

Figure 8. Diagram of Ice Harbor Lock and Dam

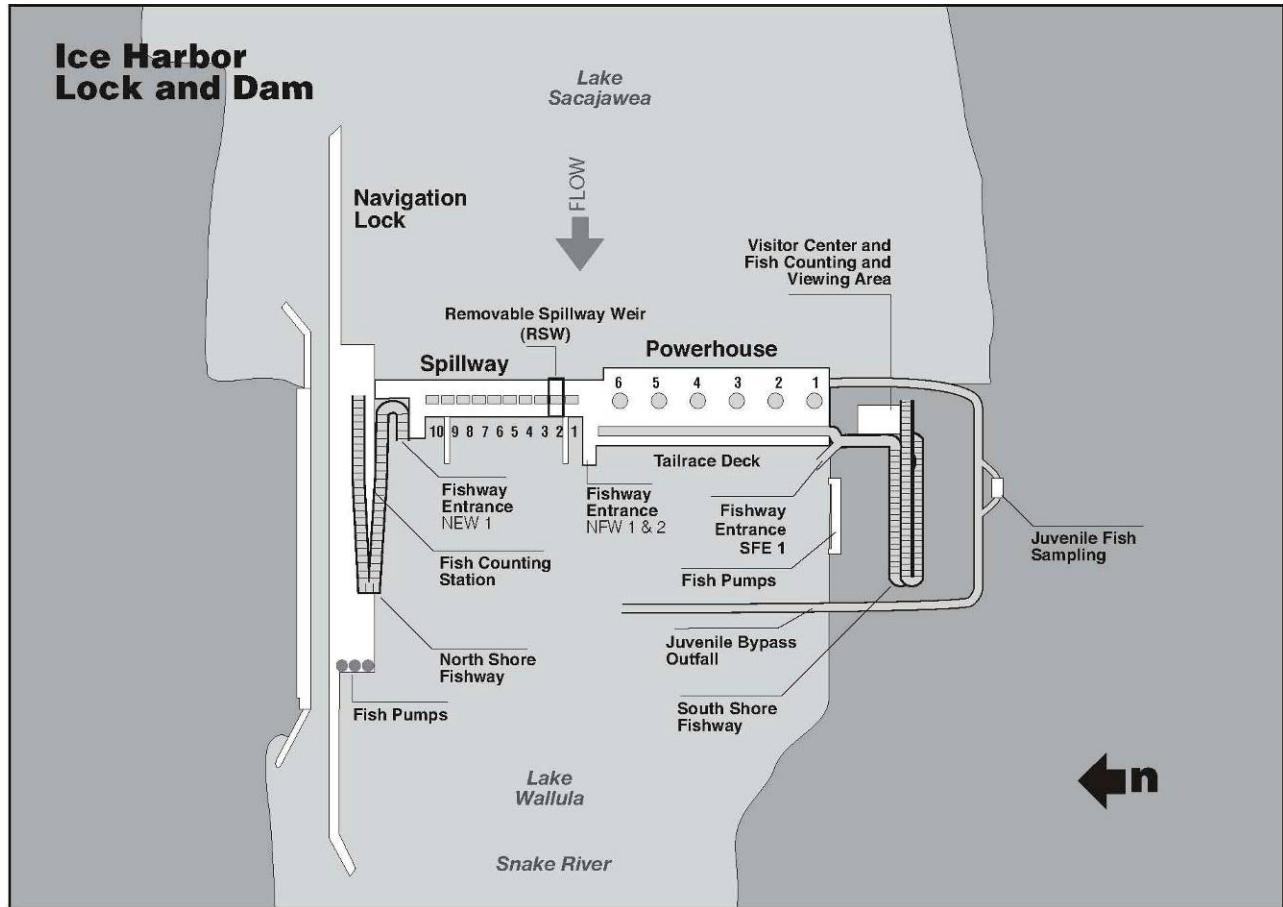

1.2.6. Lower Monumental Lock and Dam

Lower Monumental Lock and Dam is located 41.6 miles upstream from the mouth of the Snake River (see Figure 1). Completed in 1969, the project includes a powerhouse, spillway, navigation lock, and fish passage facilities (Figure 9). The powerhouse contains six 135 MW turbines housed in the 656 feet long concrete powerhouse structure. All turbine units are 312-inch diameter Kaplan, six-blade units operating at 90 revolutions per minute. Three BLH turbines were installed in 1969 as part of the original dam construction. Units 4 through 6 are AC turbines installed in 1979 under the powerhouse expansion contract. Turbine unit 1 is presently welded in a fixed-bladed position, and the remaining five turbines have full Kaplan configuration.

The intakes for all six turbine units are screened with a STS. The Lower Monumental turbines are operated within 1% of the best efficiency in accordance with the current FPP. Additional details of the operational requirements at Lower Monumental can be found in the FPP and in the project's appendix to this report.

Figure 9. Diagram of Lower Monumental Lock and Dam

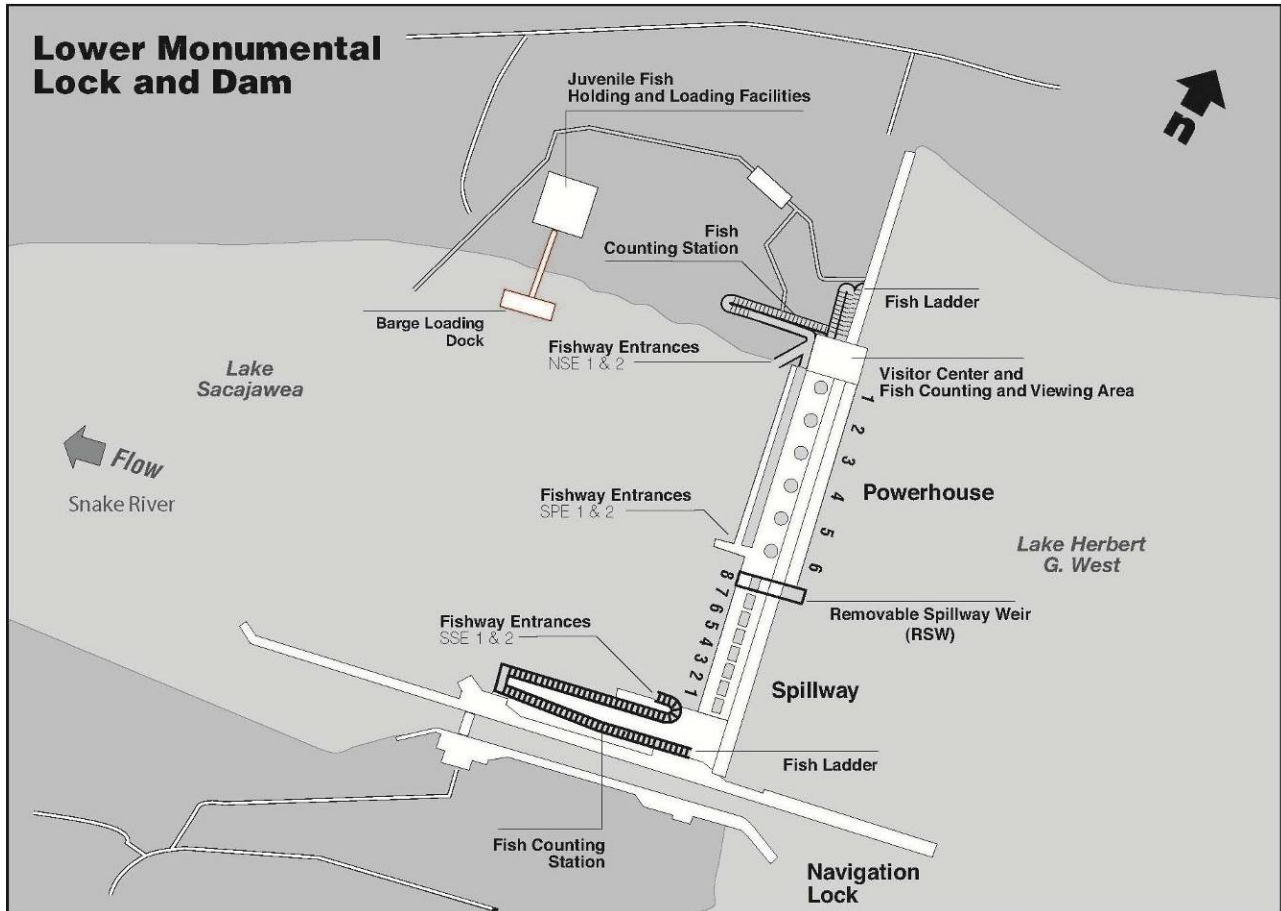

1.2.7. Little Goose Lock and Dam

Little Goose Lock and Dam is located 70.3 miles upstream from the mouth of the Snake River (see Figure 1). Completed in 1970, the project includes a navigation lock, spillway, powerhouse, and fish passage facilities (Figure 10). Little Goose has six turbine units, three BLH units and three AC units. Turbine units 1-3, from south to north, have BLH turbines installed in 1970 as part of original dam construction. Units 4 through 6 are AC turbines installed in 1978 under the powerhouse expansion contract. The turbine runners match the runners installed at Lower Monumental Dam. All turbines presently have full Kaplan configuration.

The intakes for all six turbine units are screened with an ESBS. The Little Goose turbines are operated within 1% of the best efficiency in accordance with the current FPP. Additional details of the operational requirements at Little Goose can be found in the FPP and in the project's appendix to this report.

Figure 10. Diagram of Little Goose Lock and Dam

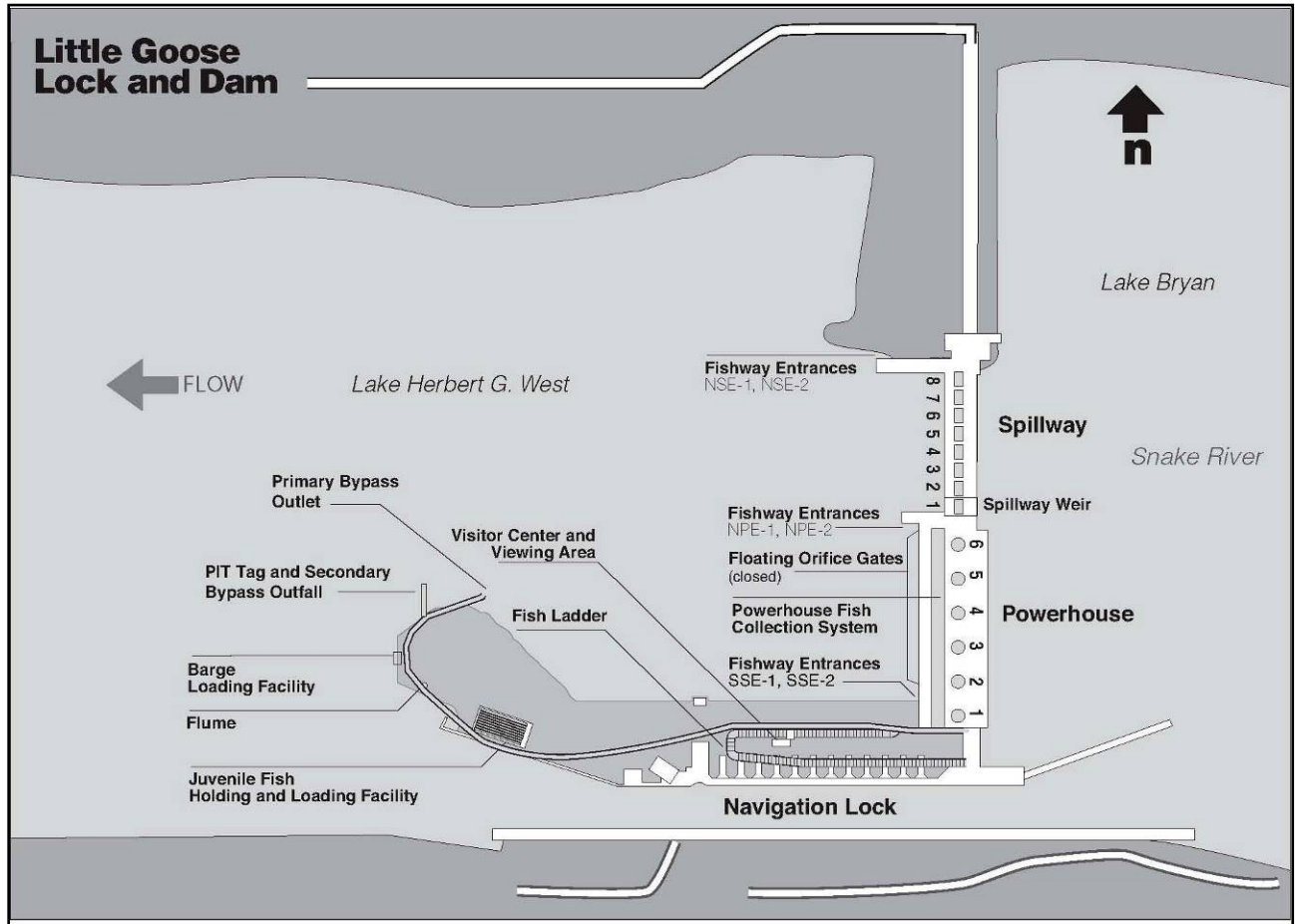

1.2.8. Lower Granite Lock and Dam

Lower Granite Lock and Dam is located 107.5 miles upstream from the mouth of the Snake River (see Figure 1). Construction started in 1965 and the project went into operation 10 years later. The project includes a navigation lock, spillway, powerhouse, and fish passage facilities (Figure 11). Lower Granite has six turbine units. Turbine units 1-3 have BLH turbines, which were installed in 1975 as part of original dam construction. Units 4 through 6 are AC turbines that were installed in 1978 under the powerhouse expansion contract. The turbine runners match the runners installed at Lower Monumental Dam. All turbines presently have full Kaplan configuration.

The intakes for all six turbine units are screened with an ESBS. The Lower Granite turbines are operated within 1% of the best efficiency in accordance with the current FPP. Additional details of the operational requirements at Lower Granite can be found in the FPP and in the project's appendix to this report

Figure 11. Diagram of Lower Granite Lock and Dam

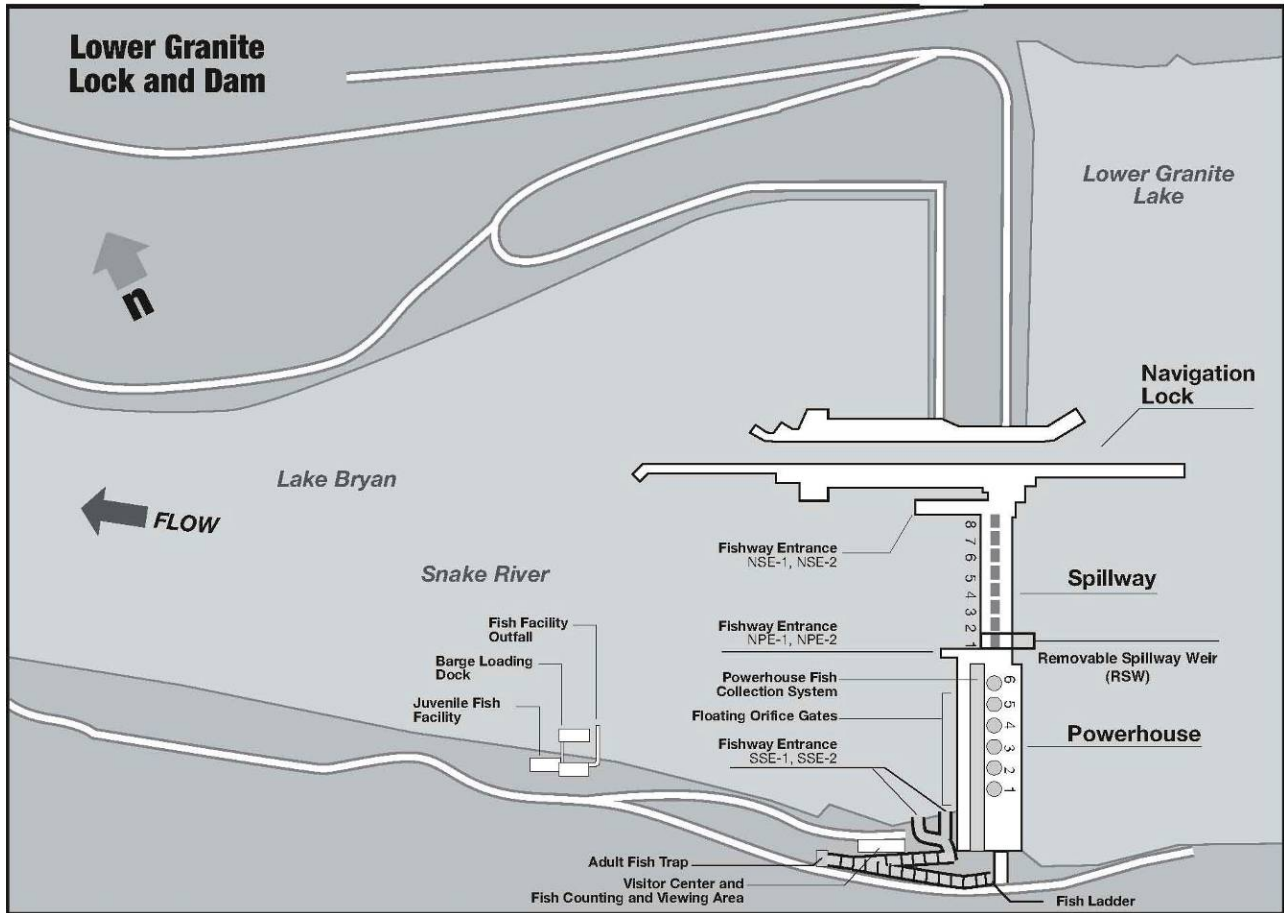

Table 1. Corps of Engineers Families of Turbines

FAMILY	DATE OF SERVICE	TURBINE MANUFACTURER	NO. OF BLADES	TYPICAL HEAD RANGE (FT)	1% UNIT FLOW (KCFS)	RUNNER DIA. (IN)	SPEED (RPM)	UNITS	PROJECT
1	1938	S. Morgan Smith	5	52 - 66	7.3 - 10.0	280	75	1-10	Bonneville I (MGR)
2	1982	Allis-Chalmers	5	52 - 66	11.6 - 18.3	331.2	69.2	11-18	Bonneville II
3	1960	Baldwin-Lima-Hamilton	6	77 - 83	8.5 - 12.5	280	85.7	1-14	The Dalles
4	1973	Baldwin-Lima-Hamilton	6	77 - 83	8.9 - 14.0	300	80	15-22	The Dalles
5	1971	Baldwin-Lima-Hamilton	6	100 - 105	12.1 - 21.6	312	90	1-16	John Day
6	1957	S. Morgan Smith	6	71 - 75	7.9 - 12.4	280	85.7	1-14	McNary
7	1962	Allis-Chalmers	6	93 - 99	8.6 - 13.7	280	90	1-3	Ice Harbor
8	1976	Allis-Chalmers	6	93 - 99	9.4 - 14.9	300	85.7	4-6	Ice Harbor
9	1970	Baldwin-Lima-Hamilton	6	97 - 100	11.1 - 19.8	312	90	1-3	Lower Monumental
	1970	Baldwin-Lima-Hamilton	6	96 - 98	11.3 - 17.7	312	90	1-3	Little Goose
	1975	Baldwin-Lima-Hamilton	6	98 - 101	11.9 - 18.6	312	90	1-3	Lower Granite
10	1978	Allis-Chalmers	6	97 - 100	14.1 - 19.0	312	90	4-6	Lower Monumental
	1978	Allis-Chalmers	6	96 - 98	13.9 - 18.9	312	90	4-6	Little Goose
	1978	Allis-Chalmers	6	98 - 101	13.7 - 17.2	312	90	4-6	Lower Granite

Note – Typical project head is the middle 80 percentile of daily project head for years 2000 to 2012

2. FACTORS IN MORTALITY OF TURBINE-PASSED FISH

The TSP Phase I report (USACE 2004) summarized the suspected causes of direct mortality of turbine-passed fish. Suspected causes of direct turbine mortality were evaluated through laboratory studies, physical hydraulic model studies, and field studies. The injuries sustained during turbine passage are split into mechanical, shear and pressure related injuries. Due to the moving and stationary structures within a turbine environment, striking and scraping of fish passing through this environment will occur. A comparison of field test results with physical model bead strike data indicates not all contact will result in significant injury or mortality. These data also indicate the frequency that fish contact turbine surfaces can be influenced by turbine operational changes. For reference, Figure 12 provides a still image of bead passage data being recorded in the physical hydraulic turbine model.

Figure 12. Passage of Neutrally Buoyant Bead through Physical Turbine Model

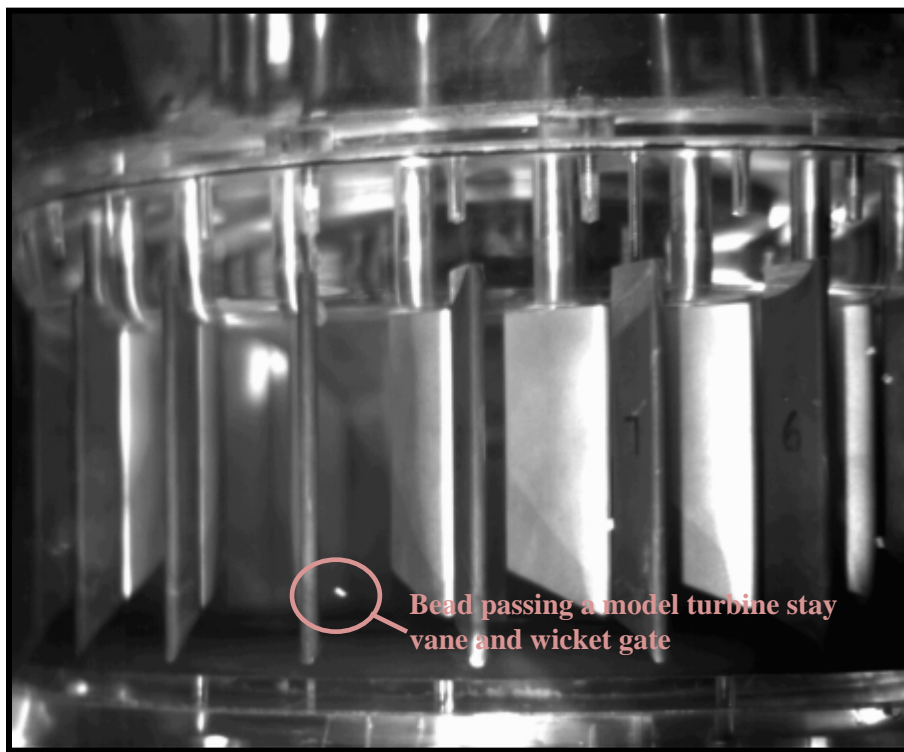

Pinching of fish at narrow passageways within the turbine environment can occur. Based on physical model studies this primarily occurs at gaps between the turbine blades and the hub, between the turbine blades and the discharge ring and between the stay vanes and wicket gates. The size of these openings and the frequency of beads getting caught in these openings, which is assumed to correlate to fish injury rate, are also dependent on operation of the turbine.

Shear and turbulence has also been shown to injure fish in laboratory studies and is suspected of being a common cause of external visible injury for turbine passed fish. A study by the Department of Energy at the Pacific Northwest National Laboratory (PNNL) exposed fish to jet velocities up to 70 feet per second (ft/s) to evaluate injury caused by hydraulic shear (Neitzel et al. 2000). This study quantified shear as a

strain rate¹ (change in water velocity over distance) based on a spatial resolution of 1.8 centimeters (cm; 0.71 inches), where this spatial interval was based on the minimum width of the salmonids tested. In general, significant injury did not result until approximately 850 cm/s/cm, which corresponds to a jet velocity of approximately 49 feet per second (ft/s) in these experiments. Similar rates of injury were seen whether the fish were pushed out the nozzle (termed fast-fish-to-slow-water) or released into the jet downstream of the nozzle (termed slow-fish-to-fast-water). Specific results do show injury at lower strain rates when introduced headfirst into the jet, as opposed to tail first as seen in Table 2.

Table 2. Fish Injury when Exposed to Shear Strain

Test Fish	# of Fish Tested	Test Orientation	Strain Rate (cm/s/cm [$\Delta y=1.8$ cm])		
			No Significant Injury	No Significant Major Injury	No Significant Deaths
Fall Chinook (age 0)	190	Headfirst	517	852	1008
Fall Chinook (age 1)	300	Headfirst	517	517	852
Spring Chinook	170	Headfirst	517	688	1008
Rainbow Trout	170	Headfirst	688	1008	1008
Steelhead	170	Headfirst	517	1008	1008
American Shad	150	Headfirst	517	517	517
Fall Chinook (age 1)	130	Tail first	688	1008	1008
Spring Chinook	130	Tail first	688	1008	1008
Steelhead	80	Tail first	852	1008	1008
Rainbow Trout	199	Headfirst w/ predators	517	NA	NA

Source: Neitzel et al. 2000

As fish pass through a turbine, they are exposed to a unique pressure time history. Pressure increases as fish approach the turbine runner, then rapidly decreases as they pass through the runner. Immediately following the runner passage, the pressure then increases as the fish enter the turbine draft-tube and flow into the tailrace. The lowest pressure experienced on the downstream or suction side of the runner is called the nadir pressure and is dependent on the turbine design, operating head, discharge, and passage location (Figure 13). Exposure of fish to pressure profiles typical of Kaplan turbines has been extensively studied. A series of laboratory studies were conducted at PNNL, where salmonids were held for 24 hours at various pressures then exposed to simulated turbine pressures (Carlson et al. 2010). Holding the fish at various pressures (termed acclimation pressures) allowed the fish to acclimate both their blood and their swim bladder to the pressure that would exist at various approach depths. These studies found the variable most responsible for injury was the ratio of the acclimation pressure to the nadir pressure. The operation of the turbine influences both distribution and magnitude of the nadir pressure.

¹ The strain rate is presented in units of cm/s/cm (centimeter/second/centimeter) to emphasize that the rate of strain is the mean change in velocity [distance divided by time (cm/s) divided by distance]. When cm/s/cm is carried through algebraically, rate of strain can be represented as 1/s. The units were left as cm/s/cm to emphasize the assumption of strain occurring over a distance of 1.8 cm (average width of the test fish). Additionally, converting the strain rates to English units does not change the numerical value of any calculated strain rates; for example, 1008 cm/s/cm is equal to 1008 in/s/in (inches/second/inches).

Figure 13. Example of Pressure Exposure during Turbine Passage

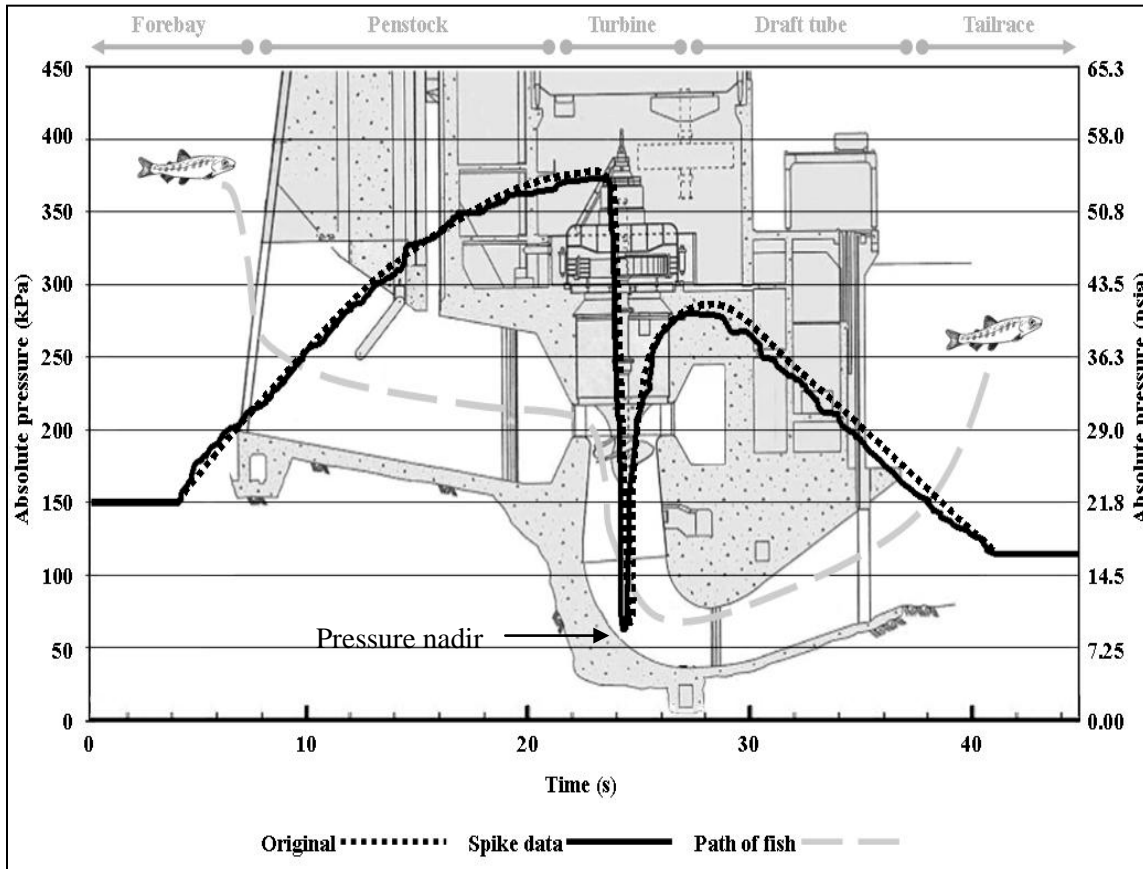

Source: Carlson et al. 2010

While the nadir pressure is a significant part of the equation for pressure related injuries, acclimation pressure is also an influencing factor. In general, juvenile salmonids approach the dams within the upper one-third of the water column during the day but may be deeper or more randomly distributed at night (Coutant and Whitney 2000). Adams and Liedtke (2010) performed studies tracking salmonids in the McNary forebay with acoustic transmitters. At first approach to the dam (approximately 100 feet out), juvenile steelhead were at a mean depth of about 10 feet, yearling Chinook at 18 feet, and subyearling Chinook at 30 feet. A comparison of incoming depth during the day and night found that yearling Chinook did not vary their approach depth much between the day and night, while juvenile steelhead went from a mean approach depth of 10 feet during the day to 18 feet at night. Given the approach depth, the majority of fish were required to dive to pass under the screens and through the turbines (Adams and Liedtke 2010).

While it appears that there is a significant approach depth difference between species, many other factors could affect the approach depth such as tag burden and/or the reservoir temperature profile. The condition of the fish's swim bladder and the dissolved gas levels within the fish's blood and body tissues as it passes through the turbine runner are unknown. Both the dissolved gas in the blood and the condition of the fish's swim bladder will influence the fish's ability to survive pressure changes. For salmon, it is known that there is a limit to the amount of air they can gulp into their swim bladder from the surface; therefore, there is a maximum to the potential depth of acclimation for the swim bladder. A

study that attempted to look at this determined that a likely median maximum acclimation depth for juvenile yearling Chinook salmon is 22 feet (Pflugrath 2012).

In addition to the mortal injury that occurs directly within a turbine environment, mortality is known to occur in tailrace following turbine passage. Indirect mortality is believed to result primarily from predation by birds and piscivorous fish. Operation of an individual turbine unit can have effect of the distribution and magnitude of velocity exiting a turbine draft tube. Additionally, reduction of non-mortal injury within the turbine environment would improve the fitness of the fish exiting the draft tube and may result in an increased ability to avoid predators in the tailrace. An indication of this effect was found in the PNNL shear strain rate laboratory studies (Neitzel et al. 2000). Predation challenge studies were performed at two different shear strain rates (Figure 14) and increased predation of jet-exposed fish over control fish for the fish exposed for the higher strain rate (but not the lower strain rate). Therefore, this study indicates that there is likely a relationship between turbine unit operations and indirect mortality (i.e., predation), but due to the limited test and lack of understanding of the strain rate seen within turbine environments, this study does little to quantify the relationship. Additionally, the total powerhouse and total project operations probably have a larger effect on indirect mortality by influencing both the egress from the powerhouse tailrace and affecting the depth, distance from shore and velocity in the tailrace.

Figure 14. Percentage of Juvenile Rainbow Trout Injured when Exposed to Headfirst Jet with Predation Challenge Performed at Two Different Jet Exposures

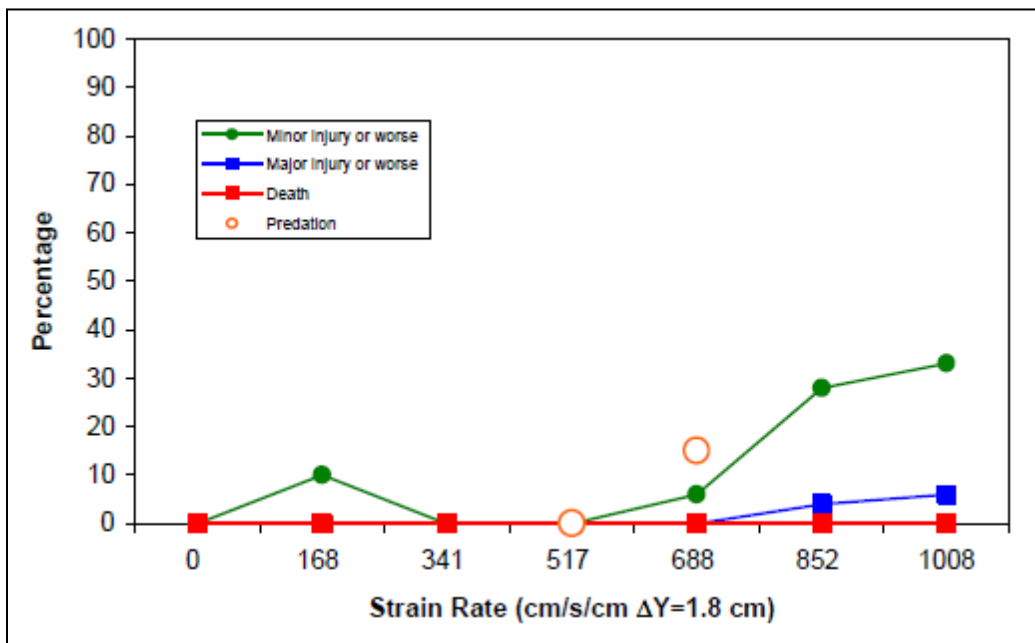

Source: Neitzel et al. 2000

3. DEFINE TARGET OPERATING RANGE FOR TURBINES

3.1. INTRODUCTION

The following information was used to help estimate the TOR for fish passage survival through the turbines at the lower Columbia and Snake River projects: (1) physical geometry of different operating conditions; (2) physical modeling data of different operating conditions that was guided by physical geometry; (3) pressure information from laboratory and field data; and (4) biological field study information. Because none of this information alone can identify a TOR for survival of fish passing through turbines, it was tied together to provide an estimate of a TOR for each project. A summary description of the information used to help estimate the TOR for fish passage survival at each project is provided below. Additional information can be found in each project's appendix to this report.

3.2. PHYSICAL GEOMETRY CONSIDERATIONS

Field studies of the McNary and John Day turbines indicate a higher probability of survival for juvenile Chinook salmon when passing through a turbine operated with a "more open geometry" (Normandeau 2003, 2007), which is sometimes beyond the current upper 1% operating limit. The turbine unit has an open geometry when the wicket gates are well aligned with the stay vanes, and the runner blades are at a steep rather than flat angle. It is relatively simple to determine and thus, is a good starting point for a particular turbine family. This alignment may be considered a reasonable starting point for optimizing fish survival through turbines. It is predicted that improved geometry will provide for a relatively uniform flow through the runner and minimizes exposure to impact, shear, and turbulence. Alignment of stay vanes with wicket gates also would reduce the wake generated between these structures.

A study of stay vane and wicket gate geometry was performed by the Hydroelectric Design Center (HDC) for the lower Columbia and Snake River hydropower projects (Wittinger et al. 2010). The purpose of the study was to identify the geometry of the different families of turbines to determine the TOR that appears to provide good alignment of the wicket gate opening to the stay vane angular position. Good alignment was considered the presentation of minimal cross-sectional area of the combined wicket gate and stay vane profiles to the flow entering the turbine runner. For comparison, information was also provided for the current operating points with or without fish screens installed.

The best physical alignment of stay vanes and wicket gates for each project is presented in Table 3. However, the goal of minimizing the gap between wicket gate and stay vanes, and maintaining the wicket gate within the hydraulic shadow of the stay vane, is expected to occur within the broader range of a wicket gate angle for each of the projects; thus, Table 4 presents this broader range. For many of the projects, the generator limit factors into the upper range, and the upper range would be compressed for larger than average project heads for these units. The gross head presented is close to the average project head for each project. Over the normal project head, the flow rates indicated would not be expected to vary much, although the power and efficiency, and to a lesser degree the wicket and blade angles, will vary over the normal project head range.

The results of the study by Wittinger and others (2010) indicate that a good geometric relationship is often not found within the existing 1% operating limits. This may indicate that adjustment of current turbine operating criteria is warranted to reduce injury and direct mortality of migrating salmon.

Table 3. Approximate Best Wicket Gate Geometry

Project and Turbine Units	Gross Head (feet)	Approximate Best Geometry				
		Wicket Gate Angle (degrees open)	Blade Angle (degrees open)	Power (horsepower)	Flow (kcfs)	Efficiency (percent)
Bonneville 1st 1-10 New MGR	60	40.50	28.6	69,500	11.0	92.60
Bonneville 2nd 11-18	60	40.86	24.0	105,000	17.3	89.20
The Dalles 1-14	80	41.00	35.0	83,500	10.1	90.80
The Dalles 15-22	80	39.00	33.3	134,000	16.6	89.15
John Day 1-16	95	41.00	31.5	200,500	21.7	85.70
McNary 1-14	75	43.00	26.3	103,000	14.4	84.30
Ice Harbor 1-3	90	40.00	30.7	141,626	17.1	81.10
Ice Harbor 4-6	90	40.50	33.0	173,600	19.8	86.00
Lower Monumental 1-3	100	41.00	32.4	199,000	19.8	88.70
Lower Monumental 4-6	100	42.00	26.5	193,000	18.7	90.90
Little Goose 1-3	95	41.00	31.9	185,000	19.9	86.20
Little Goose 4-6	95	42.00	27.0	187,000	19.4	89.30
Lower Granite 1-3	100	41.00	32.9	200,000	21.2	83.20
Lower Granite 4-6	100	42.00	27.3	192,000	19.7	85.80

kcfs = thousand cubic feet per second

Table 4. Best Wicket Gate Geometry Operating Ranges

Project and Turbine Units	Gross Head (feet)	Best Geometry In		Maximum Design	Best Geometry Operating Range				
		Existing 1% Limits? (Yes/No)	Generator Limits? (Yes/No)	Wicket Gate Operating Angle (degrees open)	Wicket Gate Angle (degrees open)	Blade Angle (degrees open)	Power (horsepower)	Flow (kcfs)	Efficiency (percent)
Bonneville 1st 1-10 New MGR	60	N	Y	61.78	37 to 43	24.0 to 31.0	59,500 to 82,500	9.3-13.4	93.9 to 90.4
Bonneville 2nd 11-18 (see Note)	60	N	N	57.00	N/A	N/A	N/A	N/A	N/A
The Dalles 1-14	80	Y	Y	54.00	37 to 45	30.0 to 35.0	72,500 to 102,500	8.8-12.7	90.2 to 89.9
The Dalles 15-22	80	N	Y	50.00	35 to 39.25	29.3 to 34.3	118,000 to 134,500	14.3-16.6	90.5 to 89.1
John Day 1-16	95	N	Y	50.00	36 to 43	26.2 to 33.6	155,800 to 212,400	16.7-23.1	86.4 to 85.1
McNary 1-14	75	N	Y	61.40	38 to 48	24.0 to 29.8	94,000 to 116,000	12.9-16.4	85.4 to 83.2
Ice Harbor 1-3	90	N	Y	53.50	39 to 40	29.0 to 30.7	136,250 to 141,626	16.3-17.1	81.8 to 81.1
Ice Harbor 4-6	90	N	Y	49.50	39 to 41	32.5 to 33.5	172,900 to 174,000	19.6-19.9	86.1 to 85.8
Lower Monumental 1-3	100	N	Y	50.00	36 to 45	27.5 to 35.0	162,500 to 212,400	16.0-21.4	89.6 to 87.4
Lower Monumental 4-6	100	N	Y	51.23	36 to 44	20.25 to 29.0	155,500 to 212,400	14.9-20.9	91.8 to 89.3
Little Goose 1-3	95	N	Y	50.00	36 to 46	27.3 to 35.0	152,000 to 212,400	15.9-23.5	88.4 to 83.7
Little Goose 4-6	95	N	Y	51.23	36 to 47	22.6 to 31.25	150,000 to 205,000	15.4-21.2	90.5 to 85.8
Lower Granite 1-3	100	N	Y	50.00	36 to 42	26.8 to 34.0	140,000 to 212,400	14.4-22.8	85.5 to 82.2
Lower Granite 4-6	100	N	Y	51.23	36 to 45	21.0 to 29.9	156,000 to 212,400	15.6-22.2	88.1 to 84.3

Note: Bonneville 2nd wicket gates do not shadow the stay vanes.
kcfs = thousand cubic feet per second

3.3. PHYSICAL OBSERVATIONAL MODEL INFORMATION

3.3.1. Overview

Physical observational model studies have been performed for multiple different turbine designs and different projects at the Engineering Research and Development Center (ERDC) in Vicksburg, Mississippi. The models typically are a 1:25 scale single unit sectional powerhouse observational models used to assess hydraulic passage conditions. These models are constructed primarily of Plexiglas allowing unobstructed views of the flow passage routes. The models are set using the Froude method and can be operated at several different heads. The appropriate scaling of gravitational (mass) and inertial (velocity) forces permits the determination of prototype conditions from model observations. The primary investigation methods include observing dye, neutrally buoyant beads, and air bubble passage through the turbine passage routes. Neutrally buoyant bead passage is observed with high-speed video and scored for both change in direction and contacts to allow a quantitative comparison of fish passage conditions at different operating points. Velocity measurements using a Laser Doppler Velocimeter (LDV) are often taken at several cross sections to obtain important flow distribution information for the turbine passage route. An ERDC technical report for the B1 Turbine Modeling (still in draft) will give more information on a typical turbine modeling effort.

These models allow detailed evaluations of how turbine operations affect impact, shear, and turbulence within the turbine passage environment and when available, provide important information. While several turbine units have been investigated, there are also several turbine units without these Froude-scale physical model investigations.

In an effort to reduce the cost and avoid duplication of building identical turbine models, a geometric and dimensional study of Kaplan turbine water passages was conducted by HDC (2005) to identify the USACE hydropower projects that can utilize the same turbine model with little or no modification. Three design categories for identifying similar families of hydropower units were developed: (1) interchangeable (identical, no modifications to the model), (2) partially interchangeable (some elements identical, only slight or minor modifications to the model), and (3) exclusive (unique design, requires unique model). The study results are shown below.

- **Exclusive:** B1, B2, and McNary turbine units are exclusive and require a unique turbine model.
- **Partially Interchangeable:** The Dalles turbine units 1-14 and units 15-22, and separately Ice Harbor units 1-3 and units 4-6, are partially interchangeable (more investigation required to verify the interchangeability of the different components).
- **Interchangeable:** John Day turbine units 1-16, Little Goose units 1-3, Lower Granite units 1-3, and Lower Monumental units 1-3 are interchangeable. Separately, Little Goose units 4-6, Lower Granite units 4-6, and Lower Monumental units 4-6 are interchangeable.

3.3.2. Bonneville Dam

3.3.2.1. First Powerhouse (B1)

A physical observational model of a single B1 turbine unit was constructed and tested at ERDC. The prototype flow rates fully investigated were 7.5 thousand cubic feet per second (kcfs), 9.7 kcfs, and 11.5

kcfs, while 7.3 kcfs and 13.4 kcfs were only qualitatively investigated. The majority of testing was conducted at 55 feet of head (prototype scale), which is close to the spring fish passage season head, but 60 feet of head was also investigated (~ summer season) with few differences found. These flow rates in relation to the 1% efficiency range are respectively, peak, upper 1%, and upper 2%, while the qualitatively only flow rates represent lower 1% and generator limit, respectively. Testing was performed without intake screens since that is the current field condition.

The first area presenting a chance of strike injury is in the vicinity of the stay vanes and wicket gates. While the contacts and direction changes showed very little change across the operating points, the gap passage decreased with increasing flow and improved alignment. The stay vanes at turbines in B1 are one of the few stay vanes that are shaped, which may explain why little change exists across the operating range for contacts and direction changes. Although the lack of improvement in contacts and direction change dilutes the conclusions, the gap passage improvement would point to higher discharges for improved passage past these structures similar to the wicket gate geometry considerations.

The next area for potential mechanical injury is for fish passing the runner blades of the turbine. In general, contact with the runner was found to decrease with increasing flow rate through the runner with the percentage of severe contacts decreasing from 2.4% to 0.9%. Similarly, the percentage of severe direction changes decreased from 5.9% for the peak operating point to 2.0% for the upper 2% operating point. This corresponded well with the stay vane and wicket gates passage, as well as the blade angle geometry considerations.

Velocity measurements were made at the draft tube exit using a LDV. The draft tube has both a vertical splitter wall that divides the draft tube into two barrels (designated A and C), and a partial length horizontal splitter wall. The velocities at the draft tube exit were used to estimate the flow rate through each of these barrels. Barrel A had a much higher flow rate than barrel C, and this was relatively unaffected by the total turbine discharge. Turbulence intensity was found to decrease with increasing flow for barrel C, while turbulence intensity changed little across the operating range for barrel A.

For this physical model, bead analysis was performed for the contacts and direction changes in the draft tube elbow and around the splitter horizontal and vertical splitter piers. Minimal change was observed across the operating range for severe contacts. However, a significant decrease in severe change in direction was seen with increasing turbine discharge (decreasing from 10% to 5.7%), which agreed with qualitative observations of a vortex occurring beneath the runner for lower discharges that was not present at higher turbine discharges. It can be concluded that increased turbine discharge improves fish passage conditions in the draft tube.

Based on the physical model information for the different areas of the turbine passage all indicated that the mechanical and shear injuries should be significantly reduced by increasing flow rates up to 11.5 kcfs. Although quantitative information was not taken for the generator limit (13.4 kcfs), hydraulic conditions appeared fairly similar to the 11.5 kcfs.

3.3.2.2. Second Powerhouse (B2)

At this time, a physical model of one of the turbine units in B2 has been assembled at ERDC, but testing and observation of the model has not occurred. Since this is an exclusive model, it is unlikely that model information from a different model could be used.

3.3.3. The Dalles Dam

At this time, a runner for turbine units 1-14 at The Dalles has been received by ERDC, but a turbine model for this runner has not been constructed or tested. There are currently plans for a model to be built for The Dalles as part of plans to replace turbine units 1-14. Currently, there is no model runner available for turbine units 15 to 22.

3.3.4. John Day Dam

The John Day physical model is a 1:25 Froude-based scale model of a single turbine unit constructed and tested at ERDC. The prototype flow rates investigated were approximately 11.80 thousand cubic feet per second (kcfs), 16.30 kcfs, 18.60 kcfs, and 19.90 kcfs for the runner operated as Kaplan. These correspond to approximately lower 1%, between peak and lower 1%, and two points between peak and upper 1%. The first area that presents a chance of strike injury is in the vicinity of the stay vanes and wicket gates. The model showed that the percentage of beads contacting these structures was low. Additionally, the lowest number of contacts and direction changes seem to occur for flows larger than 16.0 kcfs. The percentage of beads passing through the gap between the stay vanes and wicket gates were also analyzed using the high-speed video. Unlike the contacts and direction changes, this percentage appears to increase with flow and be relatively unrelated to the best wicket gate geometry.

The next area for potential mechanical injury is for fish passing the runner blades of the turbine. In general, contact with the runner decreased with increasing flow rate through the runner although at the highest flow there is some increase in contacts. Increasing flow rate of course corresponds to an increase in blade angle and increased open cross-sectional area within the runner environment.

Velocity measurements were made at multiple transects near the draft tube exit using a LDV. One area that displayed a large difference between the different flow rates tested was the velocity measurements taken near the exit of the draft tube. The draft tube for John Day units has a single vertical splitter wall which divides the draft tube into two barrels (designated A and C) of equal cross-sectional area and length. Barrel A had a much higher flow rate than barrel C at the lower turbine flow rates, but the flow distributes more evenly for flow rates of 16.5 kcfs and higher. Turbulence intensity was found to decrease with increasing flow for both barrels and especially for barrel C, although there is some increase in turbulence intensity at the highest flows. The increased turbulence at lower flow rates could cause fish disorientation. While direct injury or mortality may not result, the disorientation has the potential to increase vulnerability of fish to predation.

Based on physical model information, flow rates above 16.5 kcfs (approximately above peak efficiency) show improved hydraulic conditions over flow rates below 16.5 kcfs. There is some improvement in draft tube conditions for flow rates higher than 16.5 kcfs but marginal improvements in other areas of the runner. While it is expected that mechanical and shear related injuries to fish would be reduced between peak efficiency and generator limit (compared to operating at the low end of the operating range), the collected model information shows little difference within this range.

3.3.5. McNary Dam

Additional information to reduce strike frequency, exposure to shear and turbulent environments comes from a 1:25 Froude-scale model constructed of a McNary turbine unit. The prototype flow rates investigated were 10.2 kcfs (~ best operating efficiency), 12.2 kcfs (~ upper 1% efficiency), 13.4 kcfs (~ 2% drop in efficiency), 16.5 kcfs (~ generator limit) and 17.7 kcfs (~ beyond 100% of generator limit) at

approximately 73 feet of prototype-scale head. The percentage of beads with severe contacts to the wicket gate or stay vanes decreased significantly between best operating efficiency and the upper 1% efficiency. Bead contact was lowest at 12.2 kcfs, 13.4 kcfs and 16.5 kcfs and increased slightly at the highest flow rate. For the runner, the percentage of beads with severe contacts and severe direction changes both appeared to have a general decreasing trend with increasing flow rate.

In addition to bead data, velocity data was taken at transects near the runner and at the exit of the draft tube using a LDV. The runner tangential velocity decreases with increasing flow, which shows the increased axial flow angles caused by the steeper blade angle. The draft tube in the McNary turbine units has a single vertical splitter wall that divides the draft tube into two equal sized barrels (designated A and C). While barrel A had a much higher flow rate than barrel C at the lower turbine flow rates, the flow distributes more evenly for flow rates of 13.4 kcfs and higher. Barrel C had high turbulence intensity at low flows, which dropped significantly for flow rates of 13.4 kcfs and higher. The increased turbulence at the lower flow rates could cause fish disorientation. While direct injury or mortality may not result, fish disorientation has the potential to increase vulnerability to predation.

Based on physical model information, flow rates between 13.4 kcfs and 16.5 kcfs (between upper 1% and generator limit) show improved hydraulic conditions and thus, reduced mechanical and shear injuries would be predicted within this range. It is expected that mechanical and shear related fish injuries would be reduced for turbine unit discharges within or near this range (which is above the 1% operating range).

3.3.6. Ice Harbor Dam

While there is no physical model data for Ice Harbor turbine units 4-6, there is significant physical model data collected for units 1-3 as part of the Ice Harbor turbine replacement project. The prototype flow rates investigated were 8.8 kcfs, 11.9 kcfs, 13.4 kcfs, and 14.8 kcfs. All tests were conducted between approximately 96 feet of head (prototype scale), which is close to the average head for the project during fish passage season. These flow rates in relation to the 1% efficiency range are respectively, lower 1%, approximately upper 0.5%, upper 1%, and approximately generator limit (at 96 feet of head). Testing was performed with and without the STS in the intake; however, all model data presented is with the STS installed since that is the current field condition.

The first area presenting a chance of strike injury is in the vicinity of the stay vanes and wicket gates. Modeling showed that while the gap passage increased slightly with increasing flow, the severe contacts and direction changes generally decreased with increasing discharge. Although this information is slightly conflicting, it would point to higher discharges for improved passage past these structures similar to the wicket gate geometry considerations. The next area for potential mechanical injury is for fish passing the turbine runner blades. In general, contact and direction change within the runner were found to increase with increasing flow rate through the runner. This conflicts with the stay vane and wicket gate passage data, as well as with blade angle geometry considerations.

Velocity measurements were made at multiple transects using a LDV. The draft tube for Ice Harbor units 1-3 has a single vertical splitter wall which divides the draft tube into two barrels (designated A and C) of equal cross-sectional area and length. The velocities at the draft tube exit were used to estimate the flow rate through each of these barrels. Barrel A has a much higher flow rate than barrel C at the lower turbine flow rates, but the flow starts to distribute more evenly as the total discharge increases. Turbulence intensity decreased with increasing flow for both barrels and especially for barrel C. The increased turbulence at the lower flow rates could cause fish disorientation. While a direct injury or mortality may not result, the disorientation has the potential to increase vulnerability of fish to predation.

With conflicting information for different areas of turbine passage, it is difficult to determine which turbine unit discharge would be expected to have the best fish passage conditions per the physical model information. Based on the draft tube and distributor information, the 8.8 kcfs discharge would not be the ideal passage conditions and a higher discharge would be preferred. However, due to the high velocities in the runner environment, having good hydraulic conditions in the runner would be considered a priority. Therefore, for the discharges tested, a discharge near 11.8 kcfs would likely have the best fish passage conditions based on physical model information.

3.3.7. Lower Monumental Dam

Lower Monumental operates at a different head than John Day (approximately 100 feet instead 95 feet) but its turbine units 1-3 are the same configuration as the John Day turbine units. Therefore, physical modeling information approximates the conditions in the Lower Monumental turbine units. The conclusions that the hydraulic conditions are improved for discharges above 16.5 kcfs should also apply to turbine units 1-3 at Lower Monumental.

Additionally, Lower Monumental operates at the same head as Lower Granite, and turbines units 4-6 are the same configuration as Lower Granite turbine units 4-6. While an ERDC model has been constructed and operated, only draft tube velocity at some operating points have been investigated; thus, limited conclusions can be made about fish passage from this model.

3.3.8. Little Goose Dam

Little Goose operates at approximately the same head as John Day and its turbine units 1-3 are the same configuration as the John Day turbine units. Therefore, physical modeling information approximates the conditions in the Little Goose turbine units. The conclusions that the hydraulic conditions are improved for discharges above 16.5 kcfs should also apply to turbine units 1-3 at Little Goose.

Additionally, Little Goose operates at different head as Lower Granite (approximately 95 feet instead of 100 feet), but turbine units 4-6 are the same configuration as Lower Granite turbine units 4-6. While an ERDC model has been constructed and operated, only draft tube velocity at some operating points have been investigated; thus, limited conclusions can be made about fish passage from this model.

3.3.9. Lower Granite Dam

Lower Granite operates at a different head than John Day (approximately 100 feet instead 95 feet) but its turbine units 1-3 are the same configuration as the John Day turbine units. Therefore, physical modeling information approximates the conditions in the Lower Granite turbine units. The conclusions that the hydraulic conditions are improved for discharges above 16.5 kcfs should also apply to turbine units 1-3 at Lower Granite.

A 1:25 Froude-scale hydraulic model was constructed at ERDC for a Lower Granite turbine unit 4-6. The primary purpose for constructing this model was to investigate draft tube condition and model possible modifications to the draft tube. The existing draft tube was investigated at discharge 17.6 kcfs (~upper 1%) and 22.8 kcfs (~generator limit). The flow split went from 69.8% in barrel A and 30.2% in barrel C to 53.1% in barrel A and 46.9% in barrel C with the increase in discharge. The turbulence intensity in barrel C decreased with the increased discharge but was still considered high. There was no bead data taken for stay vane cascade or the runner environment. The draft tube information seems to indicate that there are improved hydraulic conditions with increasing discharge; however, without more information,

this conclusion is probably premature. The model still exists at ERDC and will likely need to be operated to fully investigate the variation in fish passage conditions over the operating range.

3.4. PRESSURE INFORMATION FROM LABORATORY AND FIELD DATA

3.4.1. Overview

From 2006 to 2010, the USACE funded PNNL to conduct laboratory decompression tests on juvenile Chinook salmon (Carlson et al. 2010). Over 10,000 fish were tested in the Mobile Aquatic Barotrauma Laboratory (MABL) that was developed at PNNL in collaboration with USACE. One of the primary differences with previous decompression testing is that MABL allowed for holding fish at pressure with access to air, which allowed fish to become neutrally buoyant at higher pressures to simulate acclimation in deeper water. In addition, MABL allowed for highly controlled pressure exposures accurately simulating both the rate and magnitude of pressures changes observed in field measurements of turbine pressure profiles (collected with a sensor package exposed to turbine passage).

Although a number of variables were studied, only the rate of pressure change (log ratio of pressures [LRP]) and tag burden were found to be significant variables in determination of mortality due to rapid decompression. The LRP is defined as the log ratio of absolute acclimation pressure to the absolute nadir pressure. Tag burden is defined as the ratio of tag weight in water to fish weight. Equation 1 presents the probability of mortal injury for tagged and untagged Chinook salmon based on the MABL decompression testing. For untagged fish (run-of-river fish), Equation 2 is suggested for use due to the larger data set used in its generation even though the equations are very similar (Carlson and Duncan 2004).

Equation 1:
(for tagged fish) Probability of Mortal Injury =
$$\frac{e^{-5.997+4.201*LRP+0.603*Tag\ Burden}}{1+e^{-5.997+4.201*LRP+0.603*Tag\ Burden}}$$

Equation 2:
(for untagged fish) Probability of Mortal Injury =
$$\frac{e^{-5.56+3.85*LRP}}{1+e^{-5.56+3.85*LRP}}$$

Graphical representations of Equation 1 and Equation 2 are presented in Figure 15 and Figure 16, respectively. Red- and blue-hashed lines around the predicted fit for Equation 2 represent the 95% confidence intervals for mortal injury due to decompression for both hatchery and run-of-river fish (Figure 16). The hatchery and run-of-river fish had very similar mortal injury rates due to decompression as would be expected (Figure 16). The three-dimensional graphs shown in Figure 15 suggest that tag burden has a significant effect on mortal injury particularly between LRP values between 1 and 2.5.

As can be seen in the above equations, both the acclimation and the nadir pressures play an equally important role in the primary variable of the LRP. At a majority of the projects, the acclimation pressure is not well known since little vertical distribution information exists for fish entering turbines. However, if a robust vertical distribution dataset did exist, then it could only be assumed that the fish were neutrally bouyant as opposed to postively or negatively bouyant when approaching the dam or entering the turbine runner environment. Without good information, a relatively conservative acclimation depth should be used (i.e., one that results in higher mortality). The deepest acclimation depth (or highest acclimation pressure) would result in the highest barotrauma rates.

Figure 15. Decompression Mortality for Tagged Juvenile Chinook (Carlson et al. 2010)

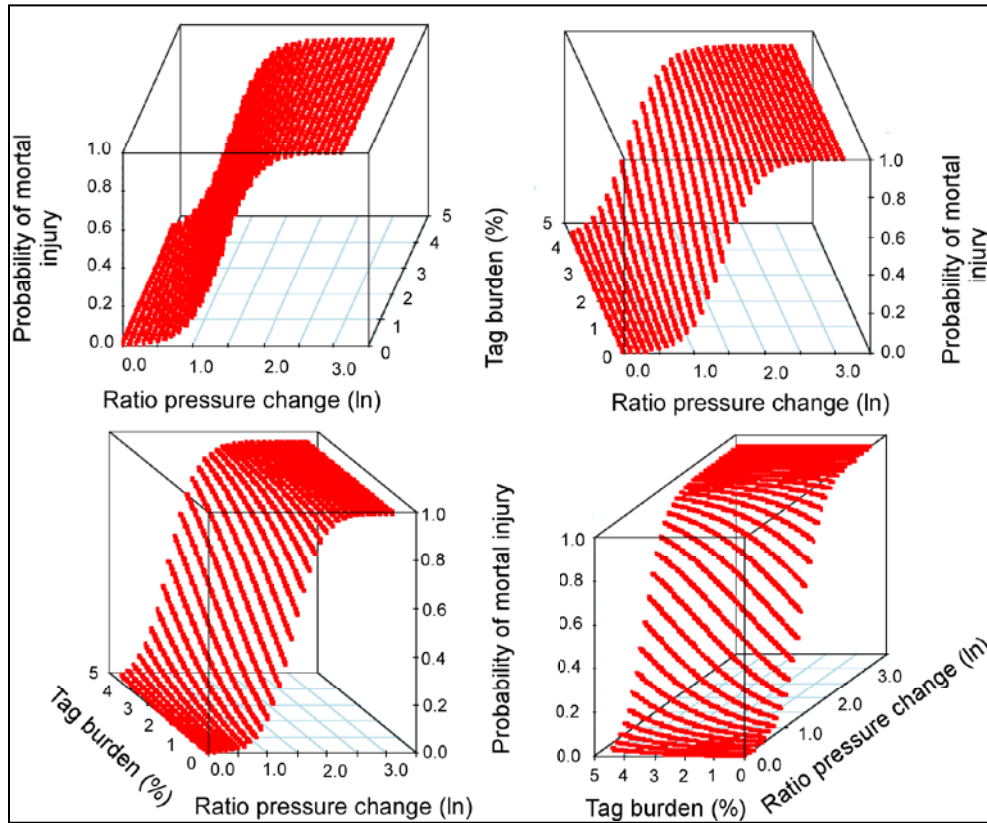
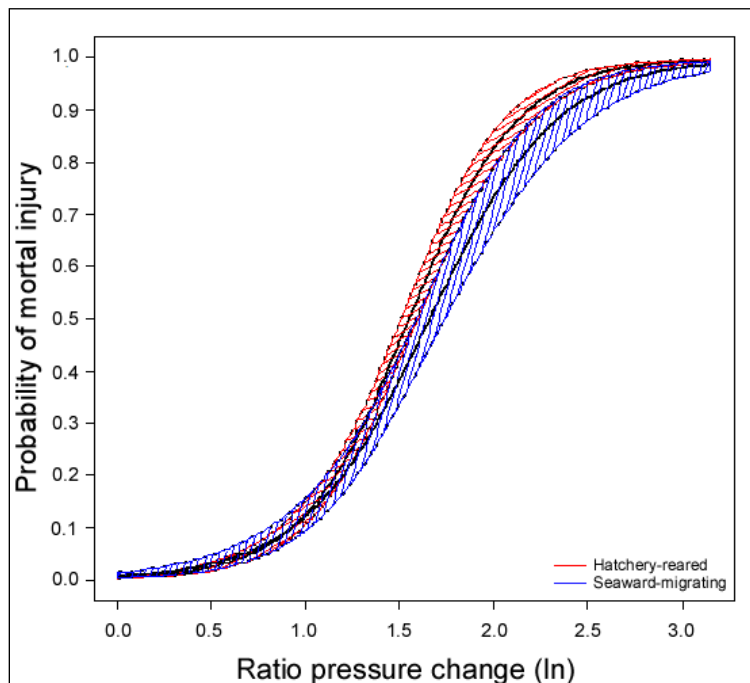

Figure 16. Decompression Mortality for In-river Juvenile Chinook (Carlson et al. 2010)



Additionally, it is known that there is a limit to the amount of air salmon can gulp into their swim bladder from the surface; thus, there is a potential maximum depth of acclimation. A study by PNNL (Pflugrath et al. 2012) looked at three different ways to estimate the deepest acclimation depth for yearling Chinook salmon. The conclusions were that a likely median maximum acclimation depth for juvenile Chinook salmon is 22 feet (Pflugrath et al. 2012). While acclimation depth for a particular project is most likely shallower, to be conservative for barotrauma rates an acclimation depth of 22 feet was used. However, improved information is being pursued for the Lower Monumental forebay, which may allow the use of a field measured acclimation depth distribution. If this information can be collected and then applied at other locations, the calculated mortality could change significantly, which may cause modification of a turbine target operating range.

3.4.2. Bonneville Dam

3.4.2.1. First Powerhouse (B1)

In winter 1999/2000, PNNL released 27 sensor fish into B1 turbine unit 6 to obtain pressure for the new MGR turbine unit and to compare it to existing turbine unit 5 (since replaced). The following four different operating points were tested at approximately 57 feet of head: 6.2 kcfs (below lower 1%), 6.9 kcfs (lower 1%), 10.4 kcfs (between upper 1% and best geometry point) and 11.7 kcfs (between best geometry point and generator limit). By releasing the sensor fish at the stay vanes, the sensor fish targeted tip, mid, and hub locations. The barotrauma mortality was calculated using the mean nadir or a pressure profile and an assumed 22-foot acclimation depth (Table 5).

Table 5. Calculated Barotrauma Mortality for B1 Turbines

Operating Point	Mean Nadir Pressure (psia)	Calculated Mortality using Average Nadir and 22-foot Water Acclimation	Calculated Fish Mortality using Pressure Profile and 22-foot Water Acclimation
6,229 cfs (below lower 1%)	17.74	1.3%	1.3%
6,850 cfs (lower 1%)	18.83	1.0%	1.0%
10,411 cfs (upper 1% to best geometry point)	19.18	0.9%	1.1%
11,693 cfs (best geometry point to generator limit)	14.02	3.1%	4.0%

psia = pounds per square inch absolute

3.4.2.2. Second Powerhouse (B2)

In 2007, PNNL released sensor fish into B2 turbine unit 16 to obtain the pressure profile at three turbine operating conditions (Carlson et al. 2008). The sensor fish were released in intake bays A and B of unit 16 but released at points that targeted either the tip or middle/hub of the turbine blade. Between 20 and 65 were released per test condition over two different discharges, 10.8 kcfs (lower 1%) and 17.6 kcfs (upper 1%). The nadir pressures recorded are summarized in Table 6. The combined data points are the tip and mid/hub data sets combined. Different pressures other than the mean nadir pressure may be experienced by fish; thus, the minimum and maximum nadir pressures are presented as well (Table 6). Based on an acclimation depth at 22 feet, the barotrauma mortality (Table 6) was calculated using the equations generated by PNNL. Note that this acclimation depth is a conservative estimate (see Section 3.4.1).

Table 6. Bonneville Turbine Unit 16 Nadir Pressures and Calculated Mortality

Turbine Passage Condition	Turbine Discharge (kcfs)	Median Nadir		Minimum Nadir		Maximum Nadir	
		Nadir (psia)	Calculated Mortality (%)	Nadir (psia)	Calculated Mortality (%)	Nadir (psia)	Calculated Mortality (%)
Lower 1% Combined	10.8	20.46	0.73	8.72	16.45	25.25	0.33
Upper 1% Combined	17.6	17.91	1.22	8.69	16.64	21.95	0.56
Lower 1% Tip	10.8	21.45	0.61	17.67	1.28	25.25	0.33
Upper 1% Tip	17.6	16.27	1.75	8.69	16.64	20.70	0.70

psia = pounds per square inch absolute. Source: Carlson et al. 2008

A pressure probability distribution can be generated that encompasses the range of pressures a fish may experience when passing a turbine runner at a given operations. This pressure distribution provides a more realistic calculation of mortality relative to simply using mean nadir pressures. With two different release points, assumptions must be made on the incoming distribution of fish. If all the nadir data points are taken as equal, the resulting incoming distribution is about 75% and would be hub/mid and at 25% would be tip passage. Using this as a basis, the pressure probability distribution for the lower 1% and upper 1% based on the sensor fish data is shown in Figure 17. Based on these pressure probability distributions and 22 feet of acclimation depth, the calculated barotrauma mortality rate is 0.89% for the lower 1% and 1.64% for the upper 1%. These values are relatively close to the mean nadir calculated values and show some increase in barotrauma rate with increasing discharge. However compared to other projects, the nadir pressures are fairly high resulting in fairly low calculated mortality.

Figure 17. B2 Nadir Pressure Probability Distribution based on sensor fish data

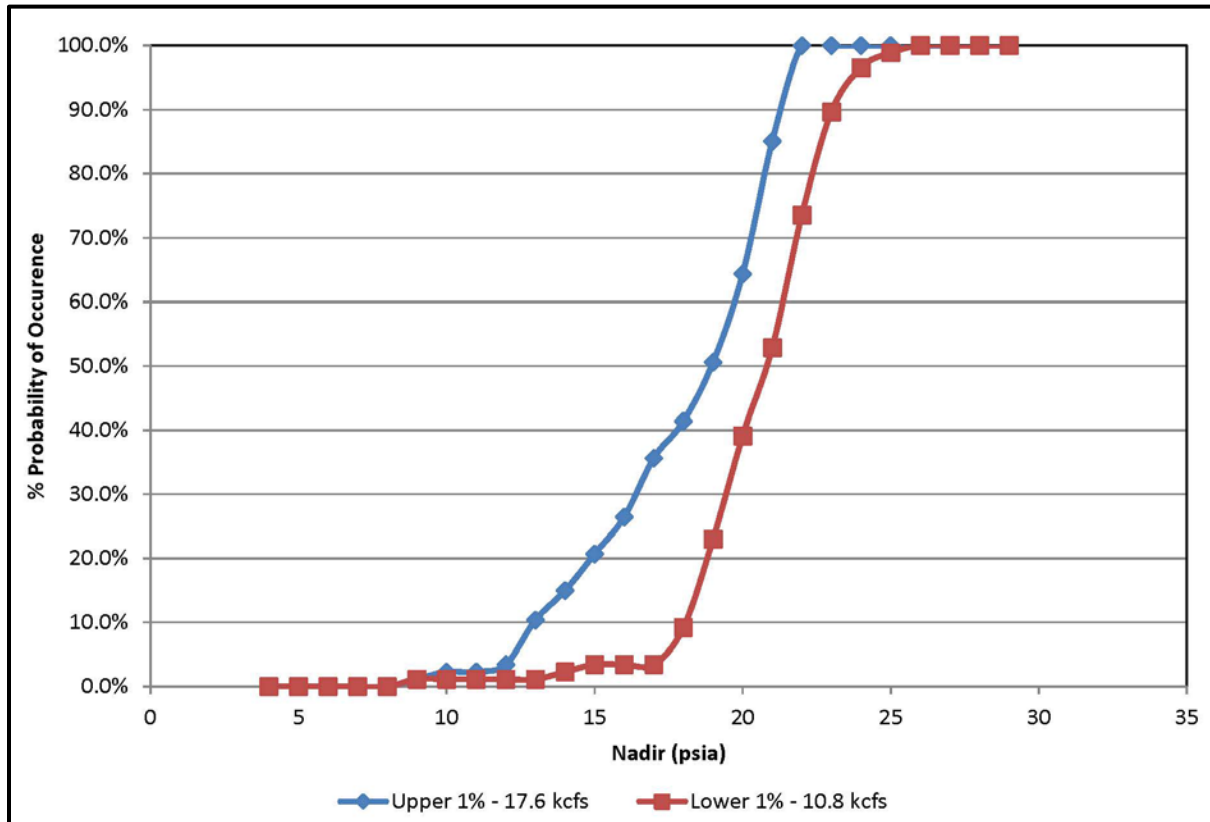

3.4.3. The Dalles Dam

There is no pressure information for either turbine units 1-14 or 15-22 at The Dalles.

3.4.4. John Day Dam

There are multiple sources of nadir pressure information for the John Day turbines. Sensor fish releases were conducted by PNNL at John Day in 2006 (Carlson et al. 2008). Following this, a computational fluid dynamics (CFD) model was developed by ENSR/VATECH of the John Day turbine environment. The USACE was then able to perform post-processing of the CFD results to generate a probability of exposure to nadir pressures. This, in turn, was compared to sensor fish and a radial offset correction was applied to the CFD to match sensor fish results (Kiel and Ebner 2011). While it is possible to use sensor fish results directly, the CFD allows for a much smoother probability curve that is not as affected by the less frequent low nadir pressures. With a more robust nadir probability curve, mortality estimates can be calculated for the full range of nadir pressure, rather than simple use of the median sensor fish result. Table 7 presents the results of the calculated mortality estimate at 22 feet of acclimation depth using both the CFD nadir distribution and point estimates from sensor fish. A great deal of variability in estimated mortality associated with the severity of nadir pressures is shown in the table; hence, these estimates should be interpreted as to what may occur at a given operation and nadir pressure. Based on this information, a large increase in estimated mortality occurs between peak and upper 1% operations suggesting that operations remain around peak to reduce the risk of barotrauma.

Table 7. John Day Nadir Pressures and Calculated Mortality

Turbine Passage Condition	Turbine Discharge (kcfs)	Calc. Mort. w/ CFD Nadir Distrib. (%)	Mean Nadir		Minimum Nadir		Maximum Nadir	
			Nadir (psia)	Calc. Mort. (%)	Nadir (psia)	Calc. Mort. (%)	Nadir (psia)	Calc. Mort. (%)
Lower 1%	11.8	0.62	22.19	0.54	0.73	99.96	30.55	0.16
Peak	16.5	1.81	21.97	0.56	14.36	2.81	27.02	0.25
Upper 1%	20.3	6.18	16.08	1.83	0.13	100.00	22.87	0.48

3.4.5. McNary Dam

An assessment of barotrauma mortality risk for McNary turbines was made using relationships established in laboratory testing and field pressure data with sensor fish. For McNary turbines, a limited amount of pressure data is available from sensor fish. In 2002, Carlson and Duncan (2004) released sensor fish in turbine unit 9 at flows of 7.7 kcfs and 16.6 kcfs. In general, the nadir pressures decreased with increasing flow, resulting in mean nadir pressures of 21.64 psia (7.7 kcfs) and 14.95 psia (16.6 kcfs). Based on laboratory studies on juvenile salmonids, 22 feet of acclimation depth for approaching fish was assumed (Pflugrath et al. 2012). Using these pressures and the generated equations, a barotrauma mortality rate without internal tags of 0.6% for 7,667 cfs and 2.4% for 16,567 cfs was calculated. A pressure probability distribution was generated but due to the limited number of sensor fish releases, the distribution was not considered accurate.

3.4.6. Ice Harbor Dam

In 2005, PNNL released sensor fish into Ice Harbor turbine unit 2 to obtain a pressure profile at three turbine operating conditions (Carlson et al. 2008). The sensor fish were released in all three intake bays of turbine unit 2 and released at points that targeted either the tip or middle/hub of the turbine blade. Between 27 and 58 sensor fish were released per test condition over three different discharges: 8.3 kcfs (lower 1%), 13.1 kcfs (upper 1%) and 14.1 kcfs (close to generator limit). The nadir pressures recorded are summarized in Table 8. The combined data points are the tip and mid/hub data sets combined; however, a tip passage was not taken for the generator limit so mid/hub only comparison was included as well. Different pressures other than the mean nadir pressure may be experienced by fish; thus, the minimum and maximum nadir pressures are given in Table 8. Based on an acclimation depth of 22 feet, the barotrauma mortality was calculated using the equations generated by PNNL (Table 8).

Table 8. Ice Harbor Nadir Pressures and Calculated Mortality

Turbine Passage Condition	Turbine Discharge (kcfs)	Median Nadir		Minimum Nadir		Maximum Nadir	
		Nadir (psia)	Calculated Mortality (%)	Nadir (psia)	Calculated Mortality (%)	Nadir (psia)	Calculated Mortality (%)
Lower 1% Combined	8.3	19.54	0.87	14.38	2.79	23.28	0.45
Upper 1% Combined	13.1	14.68	2.58	0.45	99.99	20.35	0.75
Lower 1% Mid-Hub	8.3	19.61	0.86	14.38	2.79	23.28	0.45
Upper 1% Mid-Hub	13.1	15.72	2.00	7.13	29.95	19.48	0.88
Gen. Limit Mid-Hub	14.1	15.44	2.14	6.33	40.33	19.54	0.87

Source: Carlson et al. 2008

As shown in Table 8, barotrauma rate increased with increasing discharge with a large variation from minimum to maximum nadir pressures. Instead of using mean nadirs, a pressure probability distribution can be generated at least for the upper 1% and lower 1% where both tip and mid/hub releases were completed. With two different release points, assumptions were made on the incoming distribution of fish. If all the nadir data points are taken as equal, the resulting incoming distribution is about 66% and would be hub/mid and 33% would be tip passage. Based on these pressure probability distributions and acclimation depth of 22 feet, the calculated barotrauma mortality rate is 0.87% for the lower 1% and 4.96% for the upper 1%. These values are relatively close to the mean nadir calculated values for the lower 1% but significantly higher for the upper 1%, which shows some increase in barotrauma rate with increasing discharge.

There is no pressure information for Ice Harbor turbine units 4-6.

3.4.7. Lower Monumental Dam

Units 1-3 at Lower Monumental are similar to John Day and the pressure information for John Day would likely apply to these units. Although there is no pressure data for units 4-6, there are plans to collect sensor fish information for these units.

3.4.8. Little Goose Dam

Units 1-3 at Little Goose are similar to John Day and the pressure information for John Day would likely apply to these units. Although there is no pressure data for units 4-6, there are plans to collect sensor fish information for Lower Monumental, which also would apply to these units at Little Goose.

3.4.9. Lower Granite Dam

Units 1-3 at Lower Granite are similar to John Day and the pressure information for John Day would likely apply to these units. Although there is no pressure data for units 4-6, there are plans to collect sensor fish information for Lower Monumental, which also would apply to these units at Lower Granite.

3.5. BIOLOGICAL FIELD STUDY INFORMATION

3.5.1. Overview

The majority of biological field tests completed to date for the lower Columbia and Snake River projects have provided estimates of project survival where tagged fish passed through turbines under the full range of turbine operating conditions. Total turbine passage is assigned a survival without accounting for potential survival differences across the operating range. However, a number of tests have been completed to estimate the survival under different operating conditions for the same turbine unit. Information from these tests is invaluable when available; however, there are a number of potential biases, such as that associated with barotrauma, that are factors of methodology and should be acknowledged.

The majority of turbine survival tests were performed by Normandeau using Hi-Z balloon-tag methods. To date, this method has been completed by taking surface acclimated fish and introducing them into the turbine intake under different operating conditions. Since balloon tags are external, the tag burden of internal tags will not increase measured mortality rates. However, the surface acclimation of fish also results in significant underestimation of barotrauma rates. Therefore, balloon-tag tests likely measure the portion of the direct mortality that can be attributed to contact, shear or turbulence but not pressure.

Other biological tests have been completed with internal radio or acoustic tags during turbine passage; however, the addition of an internal tag can result in a significant increase in mortality (Carlson et al. 2010). Again, these studies typically do not estimate survival for different turbine operations. Increased mortality may not be consistent across the operating range due to decreasing nadir pressures and the non-linear relationship of the barotrauma mortality rate.

3.5.2. Bonneville Dam

3.5.2.1. First Powerhouse (B1)

Normandeau Associates (2000) conducted a balloon-tag study at Bonneville Dam to compare the biological performance of a new Kaplan MGR unit to existing Kaplan units. This study compared mortality of balloon-tagged fish passing through a new MGR in unit 6 (current units) to the old Kaplan in unit 5 (has since been replaced). The study was designed as a factorial design (two turbines x three release locations x four operations). Sufficient numbers of fish were to be released so that the resulting survival probabilities would be within $\leq \pm 3\%$, 90% of the time, which resulted in 2,593 juvenile Chinook

salmon being released through the MGR unit 6 (and approximately the same number for unit 5). These objectives were accomplished by releasing fish through a specially designed induction system for fish to pass them near the blade tip, mid-blade, and hub regions in each turbine at four discrete turbine unit discharges. The study targeted four power levels but the actual average turbine unit discharges tested for the MGR turbine (unit 6) were at 6.2 kcfs (below the lower 1% operating limit); at 6.9 kcfs (approximately the lower 1% operating limit); at 10.4 kcfs (beyond the upper 1% but less than the best geometry point); and at 11.7 kcfs (between best geometry point and the generator limit). The head during the test was approximately 57 feet (same as sensor fish study since they were released at the same time). The 48-hour survival for the MGR turbine unit averaged across the release points was 3.3% (6.2 cfs), 4.3% (6.9 kcfs), 2.7% (10.4 kcfs), and 3.8% (11.7 kcfs). No statistical correlation existed between fish passage survival and turbine unit discharge in either turbine. Qualitatively, however, the highest point estimate of survival for the MGR unit, at all release locations, occurred at power level 3 (approximately 10.4 kcfs operating point).

In addition, a radio-tag study conducted in 2004 estimated direct turbine passage survival with two different control releases downstream (Counihan et al. 2006). However, this study did not separate the results by operating point.

3.5.2.2. Second Powerhouse (B2)

3.5.3. There are no known studies for turbine passage survival at different operating conditions for B2; however, route-specific survival estimates are available from 2010 and 2011 performance standard testing. Although no specific turbine operations were tested, Ploskey et al. (2012) estimated yearling Chinook turbine passage survival ($\pm 95\%$ confidence) through B2 at 95.7% (93.9 – 97.5) in 2010 and 94.7% (90.2 – 99.2) in 2011. Juvenile steelhead turbine passage survival was estimated ($\pm 95\%$ confidence) to be slightly lower compared to yearling Chinook at 91.1% (86.6 – 95.6) in 2010 and 91.1% (85.4 – 97.6) in 2011 (Ploskey et al. 2012). The Dalles Dam

3.5.4. There are no known studies for turbine passage survival at different operating conditions; however, route-specific survival estimates are available from 2010 and 2011 performance standard testing. Although no specific turbine operations were tested, Ploskey et al. (2012) estimated yearling Chinook turbine passage survival ($\pm 95\%$ confidence) through The Dalles at 87.6% (80.6 – 94.6) in 2010 and 93.0% (90.7 – 95.3) in 2011. Juvenile steelhead turbine passage survival was estimated ($\pm 95\%$ confidence) to be slightly lower compared to yearling Chinook at 88.8% (82.2 – 95.4) in 2010 and 91.9% (88.7 – 95.1) in 2011 (Ploskey et al. 2012). John Day Dam

Although a number of biological tests have estimated turbine fish passage survival at John Day, they were not designed to provide specific survival estimates at specific operating points. The 2009 Juvenile Salmon Acoustic Telemetry System estimate of survival is 72.8% for subyearling fish and 85.5% for yearling fish. The tag burden for this study was 2.6% for subyearlings and 1.5% for yearlings, which may have resulted in a biased barotrauma injury.

3.5.5. McNary Dam

Although a number of existing biological studies have estimated turbine passage survival at McNary, very few have evaluated fish passage survival relative to turbine operations. In 2002, balloon-tagged fish were

introduced into the intake of turbine unit 9 at four different operating conditions (Normandeau Associates 2003). The April releases indicated the lowest mortality occurred at 13.4 kcfs discharge (~2% drop from peak) and survival at 12.0 kcfs discharge (upper 1%) were only slightly better than 7.7 kcfs (lower 1%) and 16.6 kcfs discharges (~ generator limit). Meanwhile, a concurrent radio-tag study was conducted at McNary turbine unit 9 to estimate total turbine mortality of yearling Chinook (direct and indirect) at the 11.2 kcfs (~ between peak and upper 1%) and 16.6 kcfs operating conditions (Absolon et al. 2003).

In 2003, Perry and others (2004) conducted a study to estimate turbine survival of subyearling Chinook salmon carrying gastric implanted radio tags. The purpose of this study was to estimate turbine survival within the 1% operating range, as Skalski and others (2002) suggested that highest survival may be experienced outside the 1% operating range. Turbine operations averaged 11.5 kcfs (~ between peak and upper 1%) during the study. It was determined that survival probability was 77.4% (95% confidence interval [CI]: 70.6% - 84.2%) within the 1% operating range for subyearlings. A 2004 study by Perry and others (2006) attempted to determine a difference in survival for fish passing through turbines operating at high flows outside the 1% operating range (average 15.9 kcfs, near the generator limit), and turbines operating at lower flow inside the 1% operating range (average 11.0 kcfs; ~ between peak and upper 1%). Yearling Chinook salmon and juvenile steelhead were radio tagged with the same techniques as Perry and others (2004). Survival probabilities were highest for yearling Chinook salmon (89% - 98.6%) when turbines were operated within the 1% range and highest for juvenile steelhead (94.3% - 107.4% when turbines were operated beyond the 1% range).

Potential biases in survival estimates derived from the Absolon and others (2003), Normandeau Associates (2003), and Perry and others (2004) studies may be due to study fish being surface acclimated. Surface acclimated fish are less susceptible to barotrauma; hence, survival estimates derived from surface acclimated fish are likely not representative of actual turbine passage survival. Additionally, the radio tags used in the Absolon and others (2003) and Perry and others (2004) studies added a tag burden of nearly 5% in some cases, which may have further biased survival estimates. The Perry and others (2006) study did allow natural acclimation of fish by releasing them upstream, but study fish experienced a large tag burden as well (~ 4.5% for yearling Chinook and 2.1% for juvenile steelhead). This study found no significant difference in survival between high and low turbine discharge treatments. Small sample sizes (<100 yearling Chinook and < 30 steelhead per treatment) caused broad confidence intervals around survival estimates, which explains that the data were not robust enough to detect a significant difference in survival between treatments. This study did find an increase in mortality with distance traveled downstream between fish that passed during different discharge treatments, which suggests that turbine discharge may affect survival at McNary Dam.

In 2011, an analysis of data was conducted from tagged juvenile salmonids passing through McNary turbines from 2004 through 2009 (Adams et al. 2011). This analysis found a decrease in survival with increased tag burden for both control and turbine-passed fish, but the effect was more severe for turbine-passed fish. Turbine unit discharge was found to have no effect on fish passage survival; however, very few of the fish passed through turbines under operating conditions above the 1% efficiency range.

3.5.6. Ice Harbor Dam

In 2007, a Hi-Z balloon-tag study was conducted at Ice Harbor turbine unit 3 in all three intake slots (A, B and C) over five different operating conditions (Normandeau Associates 2008). The operating conditions tested were at the lower 1% (8.6 kcfs), at peak efficiency (~9.8 kcfs), between peak and upper 1% (11.4 kcfs), at the upper 1% (12.6 kcfs) and at the generator limit (~14.1 kcfs). The lowest survival was from Slot A for the 8.6 kcfs condition (92.9% survival, standard error [SE]=2.6%), while the highest survival was for Slot C for the 11.4 kcfs condition (99% survival, SE=1%). When all three intake bays were

pooled, the survival was 95% (SE=1.3%) for 8.6 kcfs, 96% (SE=1.6%) for 9.8 kcfs, 97.7% (SE=0.9%) for 11.4 kcfs, 96.7% (SE=1.0%) for 12.6 kcfs, and 95% (SE=1.3%) for 14.1 kcfs. Little difference was found across the operating range, but the 11.4 kcfs (between peak and upper 1%) had the highest survival for the pooled estimate. Unfortunately, no studies have been done for turbine units 4-6.

In 2008, Axel and others (2010) conducted a passage and survival study at Ice Harbor Dam. The focus of the study was to evaluate the new removable spillway weir; however, route-specific relative survival metrics were estimated as well. Radio-tagged yearling and subyearling Chinook and juvenile steelhead were released 600 meters upstream of the dam. Fish were released over a period of 27 days (24 April - 27 May). Turbine survival estimates were not operation specific and sample sizes were small, which increased the disparity in confidence intervals; however, survival estimates and confidence intervals were realistic. Survival was estimated at 94.3% (95% CI: 88.9 - 99.6%) for yearling Chinook salmon and 77.8% (95% CI: 68.5 - 87.0%) for subyearling Chinook salmon. Insufficient number of juvenile steelhead passed through turbines to provide survival estimates. Although the final report did not discuss factors influencing turbine survival estimates, subyearlings may have experienced lower survival resulting from tag burden. Summer temperatures may cause higher stress on subyearlings as well; however, fish releases ended in May when temperatures were likely not a factor affecting survival.

3.5.7. Lower Monumental Dam

Passage behavior and survival studies for radio-tagged juvenile Chinook and steelhead were conducted from 2006 through 2009 at Lower Monumental. Yearling Chinook survival rates ranged from 90.9% in 2007 (Hockersmith et al. 2008b) to 100% in 2009 (Hockersmith et al. 2010); juvenile steelhead ranged from 83.8% in 2006 (Hockersmith et al. 2008a) to 100% in 2009 (Hockersmith et al. 2010). The turbine passage survival estimates were not operation or geometry specific, nor were the numbers of fish passing through the turbines during these studies sufficient enough to provide strong survival estimates. These studies focused on spillway survival and spill patterns. Because a small percentage of fish released passed through turbines during the study, turbine passage survival may not be representative of actual survival as indicated by very broad confidence intervals in some cases. Therefore, using John Day information is likely the best surrogate for Lower Monumental BLH turbine units 1-3.

There is limited information for the Lower Monumental AC turbine units 4-6.

3.5.8. Little Goose Dam

Currently, no field studies specific to turbine passage have been conducted at Little Goose Dam; however; route-specific survival estimates are available from 2012 performance standard testing. Although no specific turbine operations were tested, Skalski et al. (2013) estimated yearling Chinook turbine passage survival ($\pm 95\%$ confidence) through Little Goose Dam turbines at 87.0% (78.1 – 95.9), subyearling Chinook at 81.3% (74.1 – 88.6), and juvenile steelhead at 80.6% (65.0 – 96.22). With the full project in operation during performance standard testing, sample sizes for turbine passage survival estimates were likely very small and may be partially responsible for the large difference in survival estimates.

3.5.9. Lower Granite Dam

Currently, no field studies specific to turbine passage have been conducted at Lower Granite Dam; however, past biological studies have provided turbine survival estimate under normal operating conditions (within the 1% range). Turbine survival estimates have been compiled and modeled for the Lower Granite Lock and Dam Configuration and Operation Plan for Meeting Juvenile Salmon

Performance Standards (unpublished draft) including turbine survival estimates. Turbine passage survival estimates were reported (low to high) for yearling Chinook salmon at 61.9 – 94.3%, subyearling Chinook salmon at 69.0 – 100.0%, and juvenile steelhead at 67.0 – 98.1%. Many of these studies may have been focusing on spillway, bypass, or overall dam passage; hence, small sample sizes may be partially responsible for the large difference in survival estimates.

3.6. TARGET OPERATING RANGE DATA SUMMARY

Using the information above, this section identifies a TOR for turbine units with currently installed turbine runners. This is a separate effort than the replacement of turbine runners to improve fish passage survival through turbines. Efforts are underway to replace Ice Harbor runner units 2, 3 and possibly 1 with units that were designed to improve fish passage. Additional turbine runners will be replaced in the future with McNary being the next for turbine replacement. Improving fish passage will continue to be a consideration in this effort. As turbine units are replaced, this document will need to be updated due to the change in operating configuration.

3.6.1. Bonneville Dam

3.6.1.1. First Powerhouse (B1)

A summary of the available information on the primary factors that affect turbine mortality at B1 is shown in Figure 19. At approximately 55 feet of head, physical injury information (physical model bead data and geometry considerations) suggests a lower rate of physical injury and mortality above approximately 8.5 kcfs extending up to the generator limit (13.3 kcfs at 55 feet of head) based on the qualitative assessment. A physical evaluation of the minimum gap runner (MGR) turbine units in this powerhouse indicated a best operating point flow level (~ 10.5kcfs) of about 1.5 kcfs higher than the current upper 1% operating range flow limit. The model bead strike analysis indicated that this flow level had significantly lower bead strike and severe direction change scores for passage conditions within the runner environment and better draft tube egress velocities than the operating points within the peak efficiency range. While no rigorous biological evaluation of the best operating point has been done to date, there was a biological evaluation of the powerhouse one MGR units conducted in 2000 (Normandeau 2000). Best geometry is defined at approximately 11.0kcfs, which is supported by the balloon-tag study which indicated a lower mortality at 10.4 kcfs even though there is not a statistically significant difference between tested operating points (Normandeau Associates 2000). Potential barotrauma mortality was derived by combining the sensor fish nadir pressure information with the laboratory-based barotrauma mortality equation using assumed acclimation depths. This data suggests that barotrauma mortality is likely lowest up to approximately 10.5kcfs; however, this is the weakest of the available data and suggests that an increase in barotrauma mortality is possible at higher turbine unit discharges. The proposed TOR for fish passage survival at B1 is defined by the shaded area of Figure 18, which is approximately 8.5 kcfs to 11.5 kcfs at 55 to 60 feet of head and encompasses the 11.0 kcfs best geometry point.

Figure 18. Combined Information on Direct Turbine Mortality for B1 Turbines

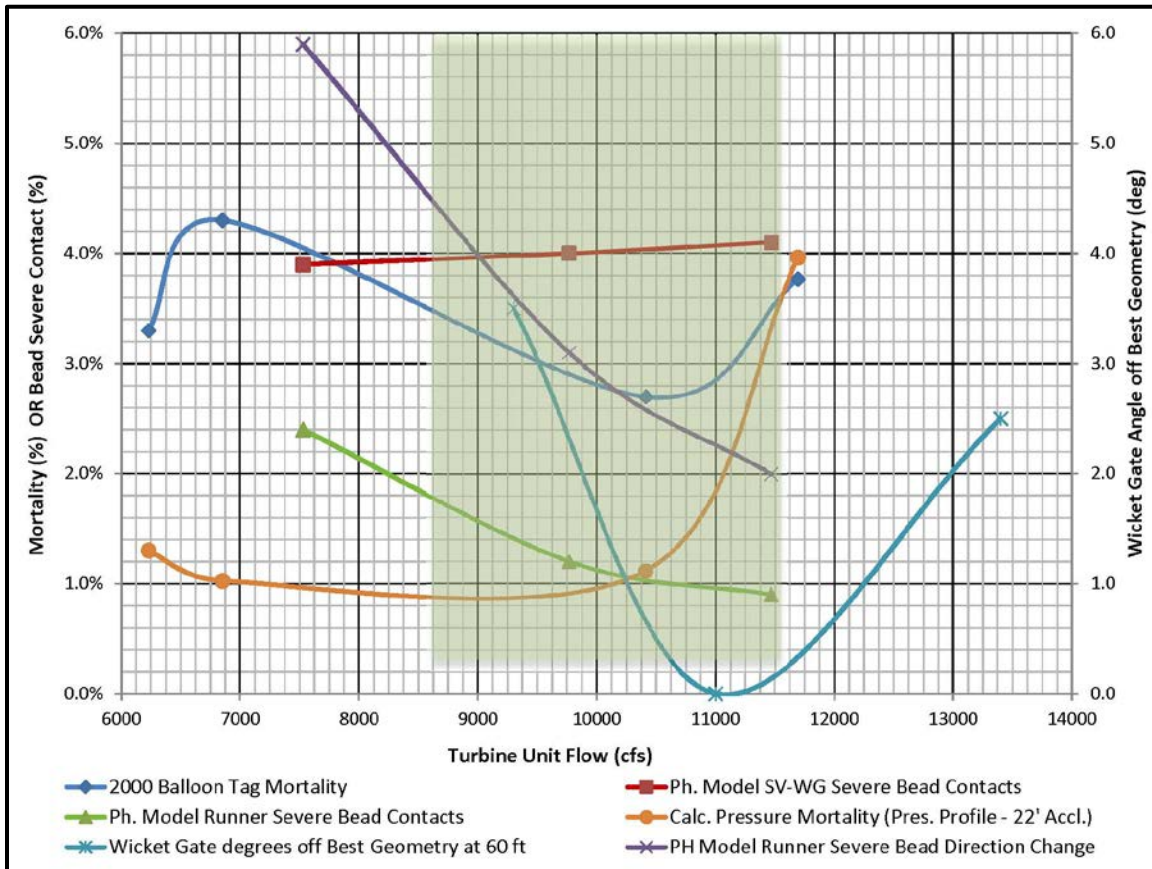

3.6.1.2. Second Powerhouse (B2)

There is limited information on pressure and geometry considerations. An ERDC model has been constructed and information from this model will likely provide additional information to identify a TOR for B2 turbines.

3.6.2. The Dalles Dam

There is only geometry information for both units 1-14 and 15-22 at The Dalles. An ERDC model needs to be constructed, a bead strike analysis conducted for a range of operations and pressure data obtained and pressure data obtained to be able to identify a TOR for the turbine units.

3.6.3. John Day Dam

A summary of the available information on the primary factors that affect turbine mortality at John Day is shown in Figure 19. Not all of the information on this graph is equal. Calculated pressure mortality and severe contacts would likely be mortalities, while direction changes and draft tube turbulence would only factor into injury and possible mortality. Therefore, by factoring in the significance of different types of information, the proposed TOR for fish passage survival at John Day is approximately 15.0 to 18.8 kcfs at approximately 100 feet of head (shaded area on graph). This is within the current 1% operating range of

approximately 11.7 to 20.8 kcfs. Therefore, there are no concerns for gateway conditions while operating in the more restricted TOR identified.

There is model and geometry information for John Day that points toward higher flows closer to the generator limit; however, the calculated pressure mortality increases significantly between the peak and upper 1% operating range. It is important to remember that the pressure mortality is calculated with a relatively conservative acclimation depth of 22 feet, but the nadir pressures are lower for the upper 1% and mortality will increase toward the upper 1% and generator limit. In selecting a range, it is also prudent to allow reasonable flexibility of operation so that the powerhouse can be operated effectively. Therefore, the low end of the operating range of 15.0 kcfs is intended to reduce the exposure of fish to the poor flow conditions past the turbine structures that appear to occur near the lower 1% operating discharge. The upper end of the operating range of 18.8 kcfs is intended to balance improved flow conditions with the increase barotrauma mortality as the flow increases through the units. It should also be noted that the 29 degree blade angle (where multiple units at John Day are fixed) is within this TOR but it is toward the upper end.

Figure 19. Combined Information for Turbine Mortality at John Day

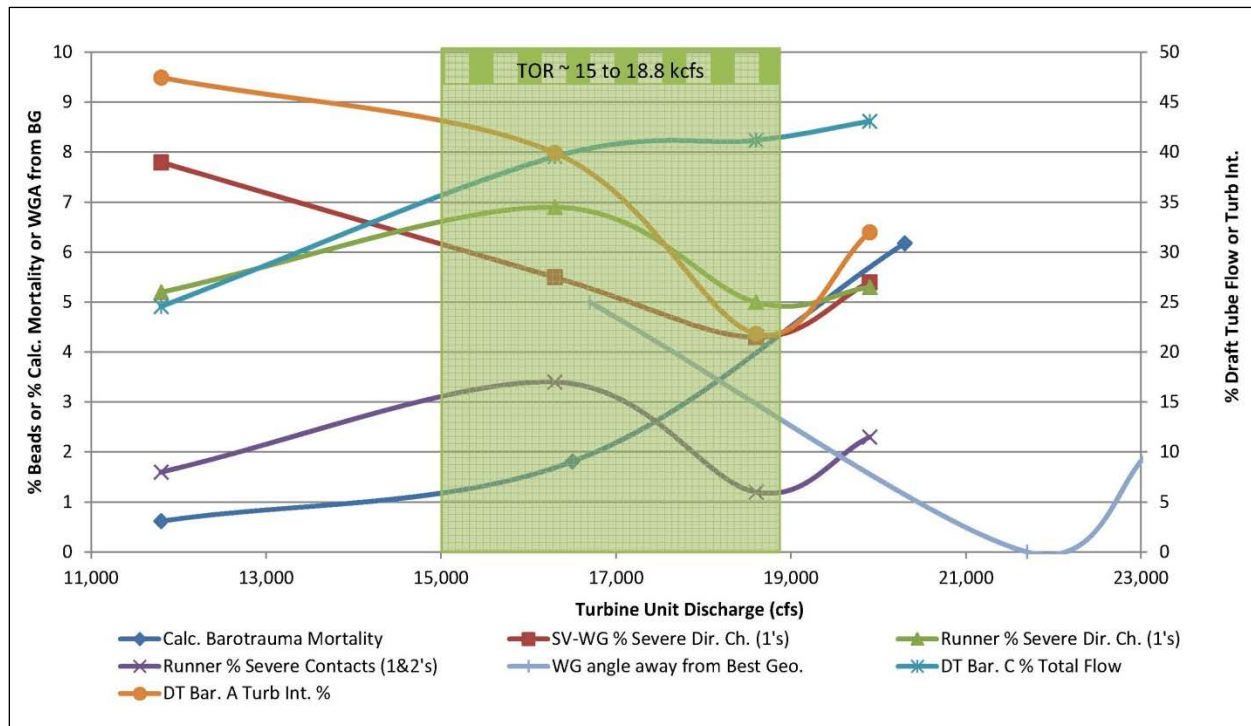

3.6.4. McNary Dam

A summary of the available information on the primary factors that affect turbine mortality at McNary is shown in Figure 20. The proposed TOR for fish passage survival at McNary is approximately 12.8 k to 15.5 kcfs at 75 feet of head (shaded area on graph). At 75 feet of head, this would correspond to a power range of 67.7 to 80.4 MW (85.4% and 83.4% efficiency, respectively), which can be compared to the current 1% efficiency range of 42.2 to 65.8 MW. Since the proposed TOR is an increase in flow rate

through a turbine as compared to current operating range, there is concern for increased injury in the JBS due to increased flow up the gatewell. This concern is discussed in more detail in Section 5.4.

Based on the physical observational model study for McNary, the proposed TOR should also reduced draft tube turbulence and thus, a potential reduction in tailrace predation. While this flow range may vary slightly with changing head, it will not vary significantly within the normal operating range for McNary. This proposed range is above the 1% efficiency operating range for McNary turbines; therefore, longer-term operation within this range would require adjustment to the FPP.

Figure 20. Combined Information for Turbine Mortality at McNary

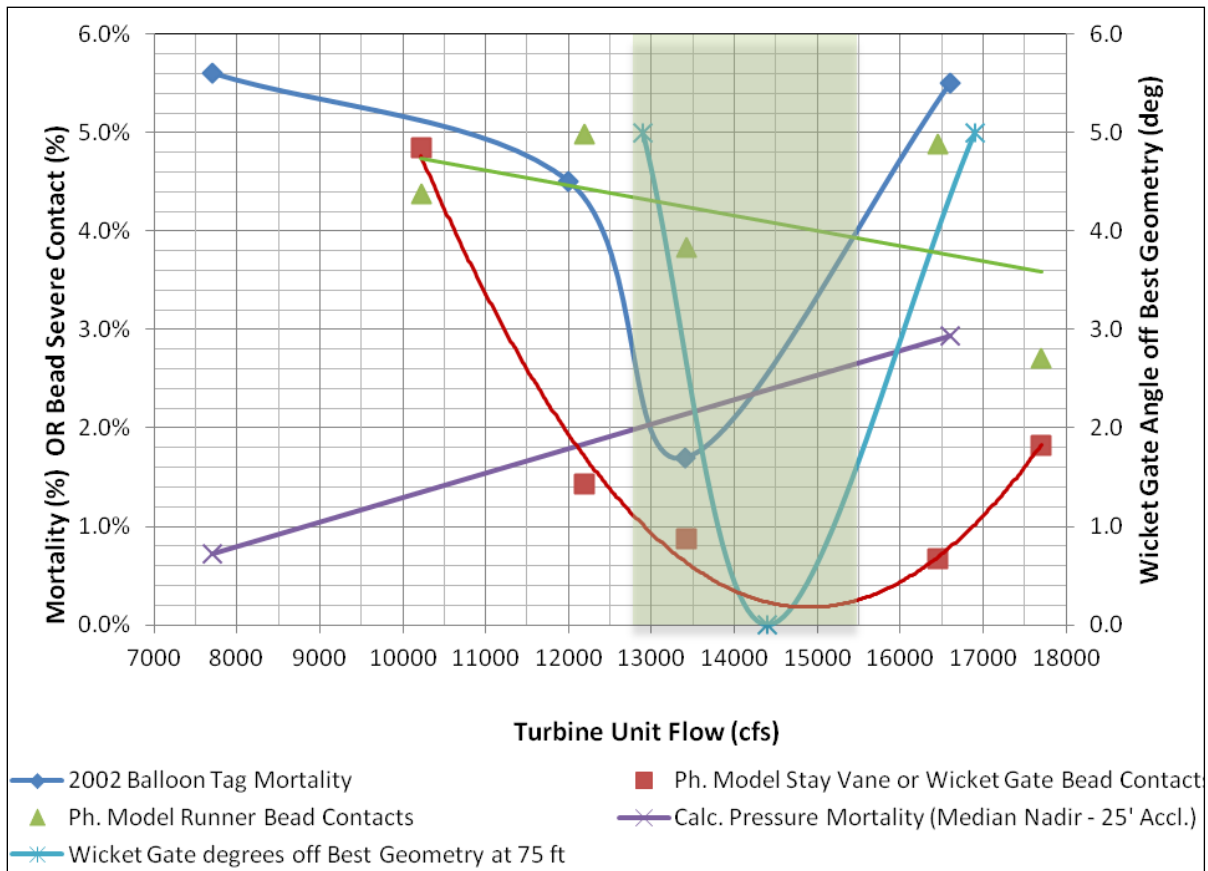

3.6.5. Ice Harbor Dam

Although CFD data is not yet available for Ice Harbor, sensor fish releases suggest that the lowest nadir pressures occur at the upper 1% and generator limit. Relative survival estimates from Normandeau Associates (2008) suggest that the lowest survival rates (~93%) occurred at the lower 1% and again at the upper 1% and generator limit. The highest survival estimates (~97%) occurred at a point between peak and upper 1%. This appears to compliment physical model data where it was determined that an operation between peak and the upper 1% provided the best passage scenario. The available information suggests that a fish passage benefit may be realized from a TOR near the 11.8 kcfs operation (between peak efficiency and upper 1%) for existing turbine units 1-3. However, pressure information indicates that there may be some increased barotrauma at the upper 1% operating point of around 13.4 kcfs. At this time, a TOR will not be fully developed for units 1-3 because these units will be replaced with new

turbine runners developed by the ongoing turbine design process that is attempting to improve fish passage conditions through the units. Units 1-3 will potentially be replaced by 2017. These units may have a TOR other than the 1% and if this is the case, this new TOR will be documented in this report or in other documents as appropriate.

Currently, very little information is available for turbine units 4-6 and no specific TOR is being recommended at this time.

3.6.6. Lower Monumental Dam

Information for John Day is likely the best surrogate for Lower Monumental turbine units 1-3. Figure 19 shows the combined information on direct turbine mortality for John Day. While it is a different dam, there is no additional information for Lower Monumental that would cause a change to this proposed range. No data currently exists for Units 4-6 at Lower Monumental.

3.6.7. Little Goose Dam

Information for John Day is likely the best surrogate for Little Goose turbine units 1-3. Figure 19 shows the combined information on direct turbine mortality for John Day. While it is a different dam, there is no additional information for Little Goose that would cause a change to this proposed range. No data currently exists for Units 4-6 at Little Goose.

3.6.8. Lower Granite Dam

Information for John Day is likely the best surrogate for Lower Granite turbine units 1-3. Figure 19 shows the combined information on direct turbine mortality for John Day. While it is a different dam, there is no additional information for Lower Granite that would cause a change to this proposed range. No data currently exists for turbine units 4-6 at Lower Granite.

4. DEFINE TARGET PROJECT OPERATIONS

The best TOR for direct turbine survival is only one component of total turbine survival. Indirect turbine mortality could be a significant portion of the total mortality and needs to be considered. Indirect mortality of turbine passed fish is thought to result primarily from predation by birds and piscivorous fish (USACE 2004). Primary ideas to reduce the high rates of indirect turbine mortality are to improve the condition of fish (reduce injury rate not just mortality) that are entering the tailrace and to improve the egress conditions out of the tailrace. Operating individual turbine units within the TOR should improve the first objective by improving the draft tube conditions. Typically, the TOR is a higher rate of flow that would provide higher and more evenly distributed velocities exiting a draft tube and thus, possibly better egress directly below a turbine unit. However, the individual turbine unit operation is unlikely to affect the egress of entire powerhouse region of the tailrace, which has much more to do with project operations than individual unit operations. A significant amount of attention has been paid to egress of spillway and JBS outfall discharge and these are the primary focus (in addition to adult fish ladder attraction) for the spill pattern and powerhouse unit priority in the current FPP. Therefore, the subsections below discuss what information is available about powerhouse egress at each project.

4.1. BONNEVILLE DAM

Bonneville Dam is unique in that each of the powerhouses and the spillway are physically separated by islands, making the egress from each section of the project nearly independent (Figures 2 and 3). The turbine unit priority for B1 and B2 in the current FPP attempts to balance adult ladder attraction with powerhouse egress. The B1 turbine unit priority is 1, 10, 3, 6, 2, 4, 5, 8, 7 and 9 (Figure 2), while the B2 turbine unit priority is 11, 18, 12, 17, 13, 14, 15, and 16 (Figure 3). For both powerhouses, the end units are operated first to provide attraction to adult ladder entrances and other units are added for egress. Typically, B2 is given priority over B1 but at times it switches. Powerhouse egress is already considered as part of the turbine unit priority and operating at the TOR should not degrade egress. Therefore, there are no recommended changes to the turbine unit priority from the current FPP.

4.2. THE DALLES DAM

The Dalles Dam is unique in that the spillway is separated from the powerhouse and the powerhouse draft tube exits are perpendicular to the main river (Figure 4). Water exiting the turbine units turns 90 degrees and then flows in a very deep channel before rejoining the spillway flow. Turbine unit priority in the current FPP prioritizes adult attraction to fish ladder entrance and to the ice and trash sluiceway, while meeting the restrictions of the transmission line needs. Due to current bathymetry and powerhouse orientation, it is not believed that much can be done to improve powerhouse egress.

4.3. JOHN DAY DAM

In March 2012, the powerhouse egress at John Day (Figure 5) was evaluated in the 1:80 general model at ERDC. The modeling concluded that the unit priorities identified in the FPP were reasonable. Block loading the powerhouse (north and south ends) does not improve powerhouse egress due to the large area between bulked flows (either powerhouse bulked flow or spillway bulked flow) causing recirculation cells moving flow upstream. When the spillway is in operation, powerhouse egress is reasonable when seven units are operational (at any unit operating point). Direct survival may increase if operating higher in the 1% operating range, but egress would diminish somewhat if that operation resulted in operating less than seven units. Powerhouse egress improves with reduced spill especially at low river flow (< 150.0 kcfs), but spill reduction is not likely due to the significantly higher survival from spill as currently tested.

4.4. McNARY DAM

Primary information on powerhouse egress at McNary comes from hydraulic modeling conducted on March 13-15, 2012, using the McNary physical model at ERDC. It was hypothesized that powerhouse egress conditions would improve with higher unit discharge and blocked loading, concentrating tailrace flow to the north near the spillway. This was observed during the modeling for the most part. In general, the velocity downstream of the north end of the powerhouse increased for conditions using the higher unit discharge of the TOR. In most cases, the increase in unit discharge also increased the velocity to over 4 ft/s, which is the generally accepted threshold for eliminating predation habitat.

Several different unit priorities were tested at different river discharges and it was concluded that the north end loading was the best unit priority. The existing turbine unit priority is unit 1 followed by units 14 through 2 (Figure 7) in the current FPP. Since unit 1 is still required for attraction flow to the south fish ladder, there is no recommended change to turbine unit priority. Although most of the testing was conducted with existing spill percentages, some testing looked at reduced spill operations. As would be expected, reducing the spill flow improved the powerhouse egress by allowing more discharge out of the powerhouse. There did not appear to be a break point on spill flow by percentage or discharge where spill egress conditions became significantly worse; some 20% spill conditions appeared to have the best project egress.

While the general model is a good tool, there are some portions of the model that do not accurately reflect field conditions, especially for entrainment. Therefore, additional information that can be used is CFD modeling for the McNary tailrace, where entrainment was essentially calibrated using dissolved gas field measurements (Politano 2012). This CFD modeling compared model simulations with the same powerhouse flow that had different unit loading and powerhouse priority – low unit loading with units 1-4, then units 14-5 priority vs. high unit loading (upper 1%) with unit 1, then units 14-2 priority. This modeling resulted in higher velocities in the north part of the powerhouse with a significant portion higher than the 4 ft/s predator habitat criteria. This higher velocity was found to push the point of powerhouse entrainment further downstream of the aerated zone causing a decrease in total river dissolved gas. It can be conjectured that these trends would continue by operating the turbine units within the higher unit loading of the TOR. Therefore, even with the increased entrainment found in the CFD modeling, the north loaded powerhouse with the higher unit flow of the TOR would be expected to result in improved powerhouse egress.

Field measurements and biological tests are needed to verify that current turbine unit priority with units operating at the TOR would improve powerhouse egress.

4.5. ICE HARBOR DAM

No information exists for Ice Harbor Dam (Figure 8) to support operations different than the current unit priority to improve egress, although further investigations are recommended.

4.6. LOWER MONUMENTAL DAM

Modeling done as recently as 2011 for the relocated JBS outfall looked at tailrace conditions at river flows from 60.0 to 90.0 kcfs and two different spill patterns (28.0 and 25.0 kcfs for each pattern). The 60.0 and 70.0 kcfs flows had a large eddy downstream of the powerhouse. In addition, data correlation was performed for turbine passage data from 2004-2009 fish survival studies. The number of units operating at Lower Monumental correlated with increased detection of fish downstream. This generally

indicates that the more units that are operating, the better the egress and the better the turbine passage survival. The turbine unit of passage at Lower Monumental also correlated with increased detection of fish downstream. Turbine unit 1 is the unit close to shore and unit 6 is closer to the center of the dam (Figure 9). This generally indicates that the closer the unit is to the center of the river, the better the egress and the better the turbine passage survival.

The powerhouse unit priority at Lower Monumental should be adjusted to pass fish through units near the spillway to leverage on the egress conditions created by spill. Unit 1 and possibly unit 2 will continue to be prioritized for adult fish attraction water, but may not be the best for juvenile salmon moving downstream due to the strong reverse eddy associated with that region at the dam. Therefore, a single unit could be used for adult attraction, while subsequent units are prioritized toward the center of the dam. Physical model operation could be used to further justify this change in unit priority.

4.7. LITTLE GOOSE DAM

No information exists for Little Goose Dam (Figure 10) to support operations different than the current unit priority to improve egress, although further investigations are recommended.

4.8. LOWER GRANITE DAM

No information exists for Lower Granite Dam (Figure 11) to support operations different than the current unit priority to improve egress, although further investigations are recommended.

5. OTHER CONSIDERATIONS

Accurately estimating turbine passage survival is important to verify TOR and evaluating adult returns may provide the most appropriate comparison of survival among passage routes. Future considerations for the comparison of turbine survival to other passage routes should include a more serious evaluation of the feasibility of draft tube PIT tag detectors. The benefit of a PIT tag detector in the draft tube is an “apples to apples” comparison of turbine survival to fish that passed other routes such as the JBS. The PIT tag data can also provide information of which passage routes a fish has experienced and how many times a particular route was passed which, over time, may suggest that greater adult returns result from one passage route compared to another. A pilot-scale effort is currently underway by the Corps Walla Walla District and a rough prototype was installed in the Ice Harbor physical model at ERDC to provide a simple observation of the hydraulic condition created by the apparatus. There is potential to develop an acceptable design from a hydraulic standpoint, but the detection efficiency of such an apparatus may not be capable of providing the information desired.

5.1. BONNEVILLE DAM

5.1.1. First Powerhouse (B1)

No further considerations affect the recommended path forward at this time.

5.1.2. Second Powerhouse (B2)

No further considerations affect the recommended path forward at this time. However, less than ideal gatewell conditions may require further operations investigations in the future.

5.2. THE DALLES DAM

No further considerations affect the recommended path forward at this time.

5.3. JOHN DAY DAM

Since the proposed TOR is within the current operating range for John Day, there should be little to no effect on the JBS. There are no other considerations that have been identified for the John Day project at this time.

5.4. McNARY DAM

The McNary turbines are currently operated with an ESBS installed in front of the turbines. This causes fish to be routed up the bulkhead gatewell slot and into the collection channel through orifices. As long as the ESBS are installed, the effect of the TOR on the gatewell environment needs to be considered in the context of achieving the highest overall project survival and lowest fish injury rates.

There has been concern that increased flow rate through the turbines at McNary may result in decreased fish health and survival in the JBS. The JBS uses the ESBS to route water and fish up the gatewell with the only route for fish to exit the gatewell being orifices that pass into a collection channel in the ice trash sluiceway at McNary. It is known that fish can spend a significant amount of time in the gatewell prior to locating and passing through the orifices. The basis of the concern is that with ESBS installed, increased

flow through the turbine results in increased flow up the gatewell. This increase in flow results in both increased velocities and increased turbulence in the gatewell, which may result in increases in fish injury and mortality. Since McNary has significant capacity above the 1% operating range, there have been multiple studies that looked at fish delay, injury and mortality at different turbine unit operating flow rates.

Table 9 summarizes all gatewell studies done to date that looked at high turbine unit loading. Since yearling Chinook was a common thread in the studies, the findings for these fish are reported in Table 9, with some subyearling Chinook data included as well. There is a large degree of variation in the descaling measured by the various studies, and the most likely cause of this variation is debris loading on the trashrack, ESBS, and VBS. Despite the variation, the overall body of data points to an increase in descaling with increased flow through the turbine unit. The quantity of this increase is difficult to determine from the studies done to date, but is probably less than a 5% increase in descaling. It should be noted that a significant portion of the descaling will not result in fish mortality; however, since this relationship is unknown, descaling should be limited to the extent possible. Although not quantified in any of the studies, all studies discussed debris as being a significant contributor to descaling.

Table 9. McNary Gatewell Fish Condition at Different Operating Conditions

Study Year	1997	2002	2004	2005	2006	2010	2010
Reference	(Brege et al. 1998)	(Absolon et al. 2003)	(Absolon et al. 2005)	(Gessel et al. 2006)	(Gessel et al. 2007)	(Axel et al. 2011)	(Axel et al. 2011)
Test Fish	Yearling Chinook	Yearling Chinook	Yearling Chinook	Yearling Chinook	Subyearling Chinook	Yearling Chinook	Subyearling Chinook
High Turbine Unit Flow Results							
High Test Q (kcf/s)	16.0	16.4	16.0	16.0	16.0	13.8	13.8
Descaling (%)	17.1	0.2	Incomplete	8.7	2.8	7 to 11	11% for U4 4% for U5
Mortality (%)	---	---	Incomplete	---	1.8	---	---
Orifice Passage	94% OPE in 24 hrs	0.58 hr avg. GW residence time	0.38 days avg. GW residence	---	---	---	---
Low Turbine Unit Flow Results							
Low Test Q (kcf/s)	12.0	11.2	12.0	12.2	12.2	12.1	12.1
Descaling (%)	6.7	0.3	Incomplete	7.7	2.5	4 to 7	4.5% for U4 2.5% for U5
Mortality (%)	---	---	Incomplete	---	0.6%	---	---
Orifice Passage	63% OPE in 24 hr	18.7 hr avg. GW residence time	0.51 days avg. GW residence	---	---	---	---

In conclusion, the multiple studies done to date point to an increased risk for fish passed through the JBS when turbines are operated at the predicted TOR (12.8 to 15.5 kcf/s at 75 feet of head). However, if debris on the trashracks, ESBS, and VBS are managed appropriately, this increase should be kept to a minimum.

5.5. ICE HARBOR DAM

No further considerations affect the recommended path forward at this time.

5.6. LOWER MONUMENTAL DAM

The standard length traveling screens used at Lower Monumental have several potentially detrimental effects on fish passing beneath them and eventually passing through the turbine. The screens cause turbulence, loss of turbine efficiency, and sometime reverse flows near the ceiling of the intake that can delay and disorient juvenile salmon passing by them. It is not clear that the bypass routes are necessarily better for survival of juvenile salmonids than turbine routes. In spring 2009, juvenile salmon survivals through the bypass system were lower (0.965 for yearling Chinook and 0.939 for juvenile steelhead) than for fish passing through the turbines (1.021 for yearling Chinook and 1.009 for juvenile steelhead). In this instance, the removal of screens during non-transport periods may have provided better survival results than leaving them in. Part of the low survival of through the bypass may have been related to its outfall location, which is not ideal under the current mandated spill patterns. The outfall is currently being relocated downstream where the egress conditions are more favorable. Regardless of the outfall relocation, bypassed fish at Lower Monumental have suffered relatively low smolt-to-adult returns as compared to other routes. It will require time and continued monitoring to determine if the smolt-to-adult returns continue to be low.

5.7. LITTLE GOOSE DAM

No further considerations affect the recommended path forward at this time.

5.8. LOWER GRANITE DAM

No further considerations affect the recommended path forward at this time.

6. RECOMMENDED PATH FORWARD

Using the available information, this section recommends turbine unit TORs and target project operations to improve fish passage survival through turbines. For some projects, there is limited information; therefore, as additional information becomes available, this report will be updated to incorporate the information and to revise the recommendations as appropriate. The regional stakeholders would need to look at the project holistically prior to adoption of these recommendations.

6.1. BONNEVILLE DAM

6.1.1. First Powerhouse (B1)

The information presented in this report indicates that turbine unit operation may have a significant effect on direct turbine mortality at the B1. Based on the available information, a TOR of 8.5 to 11.5 kcfs at approximately 55 feet of head is proposed. Figure 21 translates this flow range to generator power and efficiency at 55 feet of head, since flow is a calculated value based on power and efficiency.

Figure 21. Proposed Target Operating Range at 55 feet of Head for B1 Turbines

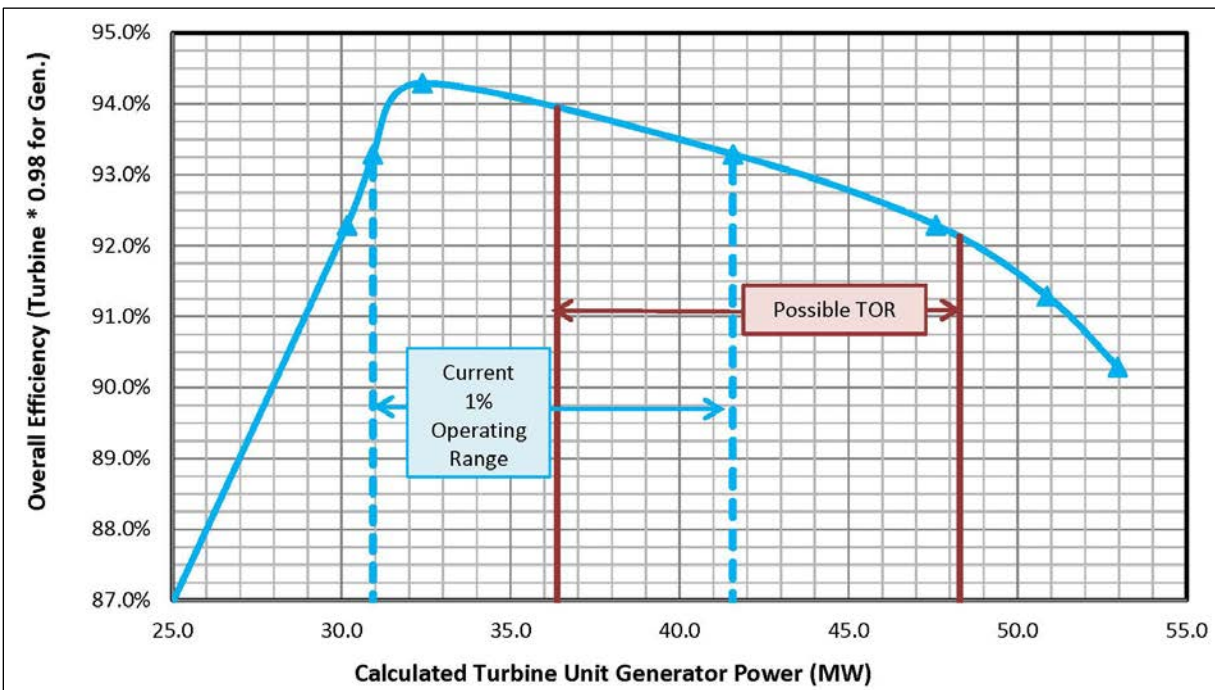

Although the proposed TOR is supported by some field studies, the TSP team believes that additional pressure information is needed to fine-tune the upper end of the operating range. Therefore, either additional sensor fish releases and/or CFD modeling should be conducted to better define the barotrauma risk. This additional information could result in a revision to the TOR. Since Bonneville can have a more significant head variation than the other hydropower projects, it is important to define the TOR at other

heads to fully implement this as a new operating range for B1 turbines. For target project operations, the existing turbine unit priority is probably adequate since the B1 powerhouse has a separate tailrace.

6.1.2. Second Powerhouse (B2)

There is not enough information at this time to recommend a different turbine unit operating range than the existing 1% requirements. For target project operations, the existing turbine unit priority is probably adequate since the B2 powerhouse has a separate tailrace.

6.2. THE DALLES DAM

There is not enough information at this time to recommend a different turbine unit operating range than the existing 1% requirements. Target project operations have also not been fully investigated although the project configuration may make it difficult to make significant improvements in turbine egress conditions.

6.3. JOHN DAY DAM

Turbine unit operation may have a significant effect on direct turbine mortality at John Day Dam. The recommended TOR is 15.0 to 18.8 kcfs at approximately 100 feet of head. At 100 ft of head this TOR range approximately equates to 108 MW to 136 MW which is within the existing 1% range. This TOR is consistent with the most open geometry and with bead strike data and draft tube conditions from the physical model, while accounting for the concerns with barotraumas and low nadir pressures at the higher operating discharges. The existing unit priority seems to give the best turbine egress given currently required spill. If possible with river discharges, operating at least 7 units reduces recirculation below the powerhouse. The TSP team proposes that a thorough turbine survival test be conducted at John Day to establish whether increased survival is seen under the TOR conditions. Indirect mortality (i.e., predation) is considered to be a large portion of total turbine mortality; therefore, any TST must make the project operating conditions as similar as possible while testing the different unit operating conditions.

Figure 22. Proposed Target Operating Range at 100 ft of Head for John Day Turbines

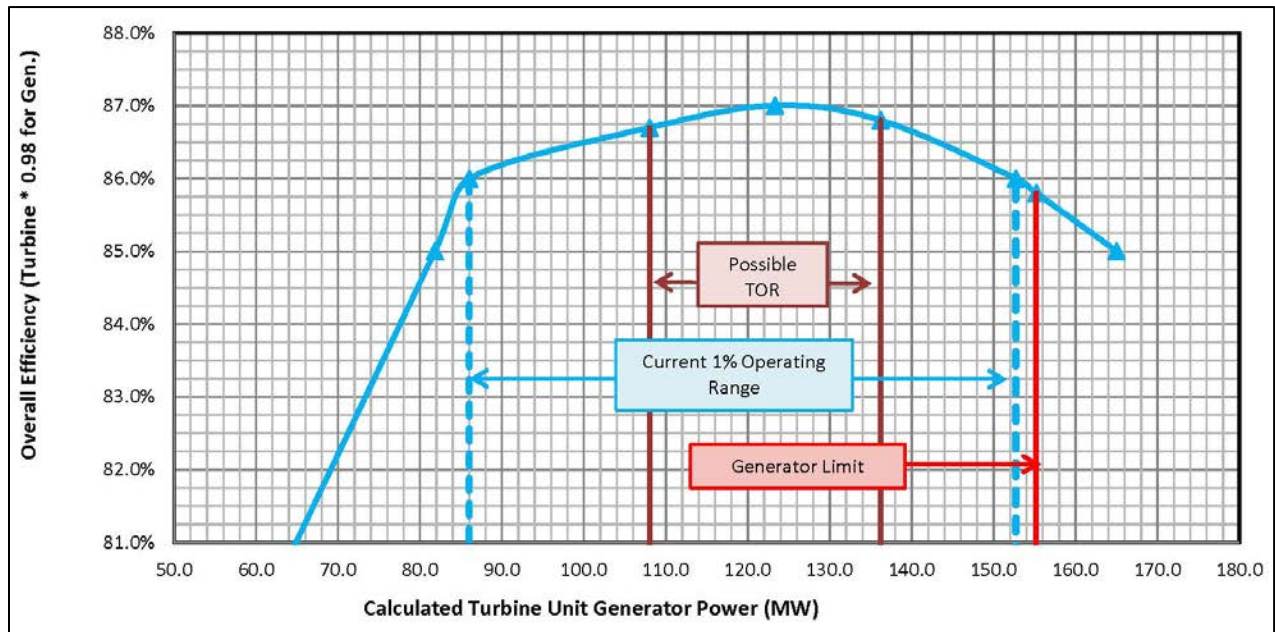

6.4. McNary Dam

Turbine unit operation may have a significant effect on direct turbine mortality at McNary Dam. Based on available information, a TOR of 12.8 to 15.5 kcfs at 75 feet of head is being proposed for McNary Dam. Figure 23 translates this flow range to generator power and efficiency at 75 feet of head, since flow is a calculated value based on power and efficiency. The TOR may increase the descaling rate of fish diverted by the ESBS into the JBS. With diligent debris management, however, it is expected that the descaling rate should be kept at a minimum. While increased JBS injury is a concern, descaling does not necessarily result in mortality; therefore, the potential benefit in total turbine survival using the TOR of 12.8 to 15.5 kcfs at 75 feet of head is worth exploring.

While the proposed TOR is supported by some field studies, the TSP team believes additional field verification is needed. Therefore, it is recommended that a comprehensive turbine survival test be conducted at McNary within and surrounding the proposed TOR of 12.8 to 15.5 kcfs at 75 feet of head (see Section 6.2). If testing determines that turbine operation at McNary within the TOR can improve the direct survival of turbine-passed fish, the TOR would need to be defined at multiple heads. It is possible to define an operating range at the full range of heads based on efficiency, wicket gate angle, blade angle, discharge or some combination of these variables. The difference in survival shown by testing at the edge of the range, as well as practical operational considerations, will need to be taken into consideration when defining the target fish passage unit operations over a range of heads.

Figure 23. McNary Turbines Proposed Target Operating Range at 75 feet of Head

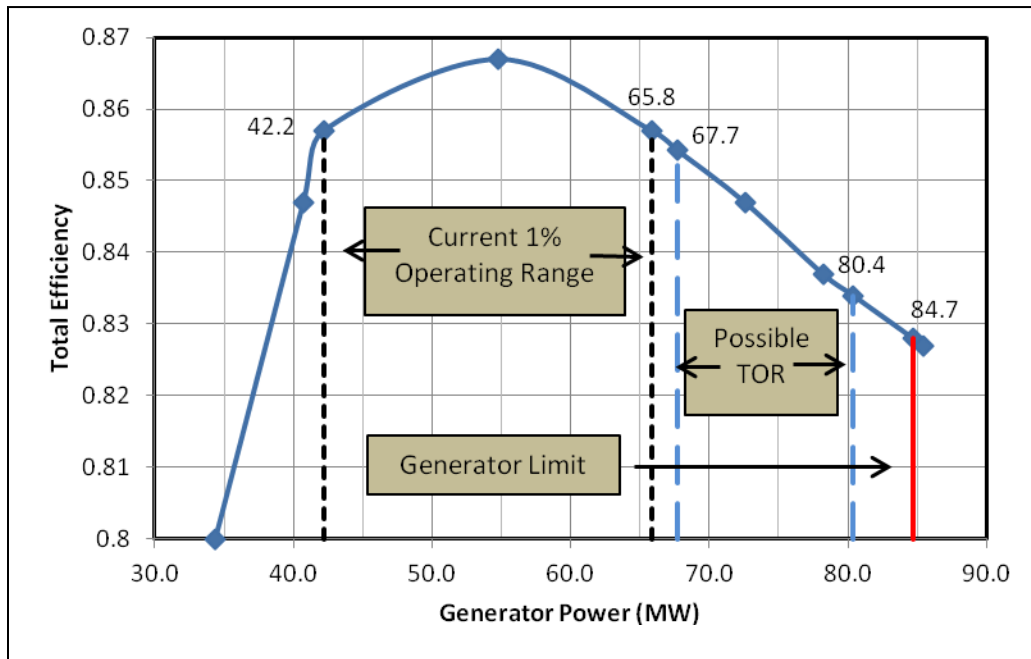

The next step would look at methods for improving indirect turbine survival. Based on the use of the McNary physical model, the current turbine unit priority (unit 1, then units 14-2), with units operating at the TOR would improve powerhouse egress. Reductions in required spill would benefit powerhouse egress without harming project egress. Spill reductions are considered unlikely at this time but could be considered as part of the Configuration Operation Plan process. Field velocity measurements and/or biological studies could verify whether further improvements to powerhouse egress and indirect turbine mortality could be made. Finally, field biological studies could be undertaken to look at total turbine survival (direct + indirect).

While the above described comprehensive approach to defining and validating the recommended TOR for McNary Dam is appropriate, future powerhouse rehabilitation potentially beginning by 2021 should be considered. Further performance standard testing as required by the NMFS BiOp (2008) resulted with acceptable survival estimates for juvenile salmonids in 2012, and may again in 2014. Changing turbine operations may require subsequent performance standard testing to ensure that overall project survival of passing fish does not suffer as a result. The proposed TOR also has the potential to divert about 3.2 kcfs/unit (or about 45 kcfs/14 units) of river flow away from the spillway during high flow, uncontrolled spill periods. While not prescribed by a BiOp or a court order, this spill does contribute to the measured project performance standards; however, the proposed TOR may also reduce required spill. For these reasons, it may be more appropriate to define the TOR of the new turbine runners during the design process and field validate post-installation.

6.5. ICE HARBOR DAM

For Units 1-3, a fully developed target operating range is not planned to be developed since these units will likely be replaced by 2017 with new units that are intended to improve fish passage. Turbines units 4- 6 are of a different design and there is not enough information at this time to develop a target operating range.

6.6. LOWER MONUMENTAL DAM

Turbine units 1-3 are the same design as John Day and the information from John Day is considered applicable to Lower Monumental. Based on this, the recommended TOR for Lower Monumental turbine units 1-3 is 15.0 to 18.8 kcfs. There is very little information for Lower Monumental units 4-6 for improved fish passage survival. Based on geometry information, a discharge between peak and upper 1% to even higher is recommended; based on unknown pressure mortality, this range should be limited to the upper 1%. The majority of operations within the $\pm 1\%$ of peak efficiency criteria for units 4-6 occur between peak efficiency and the upper 1%. Thus, turbine units 4-6, by default, operate in a preferred manner.

The powerhouse unit priority at Lower Monumental should be adjusted to pass fish through units near the spillway to leverage on the egress conditions created by spill. Unit 1 and possibly unit 2 will continue to be prioritized for adult fish attraction water, but may not be the best for juvenile salmon moving downstream due to the strong reverse eddy associated with that region at the dam. Therefore, a single unit could be used for adult attraction, while subsequent units are prioritized toward the center of the dam. Physical model operation could be used to further justify this change in unit priority.

6.7. LITTLE GOOSE DAM

There is not enough information at this time to recommend a different turbine unit operating range than the existing 1% requirements. Target project operations have also not been fully investigated and therefore there are no recommended changes to project operations at this time.

6.8. LOWER GRANITE DAM

There is not enough information at this time to recommend a different turbine unit operating range than the existing 1% requirements. Target project operations have also not been fully investigated and therefore there are no recommended changes to project operations at this time.

7. REFERENCES

- Absolon, R.F., M.B. Eppard, B.P. Sandford, G.A. Axel, E.E. Hockersmith, and J.W. Ferguson. 2003. Effects of Turbine Operating at Two Different Discharge Levels on Survival and Condition of Yearling Chinook Salmon at McNary Dam, 2002. National Marine Fisheries Service, Seattle, Washington.
- Absolon, R.F., M.H. Gessel, B.P. Sandford, and G.M. Matthews. 2005. Evaluation of Fish Condition with Prototype Vertical Barrier Screens at McNary Dam, 2004. National Marine Fisheries Service, Seattle, WA.
- Adams, N.S. and T.L. Liedtke. 2010. Juvenile Salmonid Survival, Passage and Egress at McNary Dam During Tests of Temporary Spillway Weirs, 2009. Geological Survey Western Fisheries Research Center, Cook, WA.
- Adams, N.S., C.E. Walker, and R.W. Perry. 2011. A Multi-Year Analysis of Passage and Survival at McNary Dam, 2004-09. US Geological Survey, Reston, Virginia.
- Axel, G.A., E.E. Hockersmith, B.J. Burke, K.E. Frick, B.P. Sandford, W.D. Muir, and R.F. Absolon. 2010. Passage Behavior and Survival of Radio-Tagged Yearling and Subyearling Chinook Salmon and Juvenile Steelhead at Ice Harbor Dam, 2008. National Marine Fisheries Service, Seattle, Washington.
- Axel, G.A., M.H. Gessel, E.E. Hockersmith, M. Nesbit, and B.P. Sandford. 2011. Evaluation of Juvenile Salmon Condition (Descaling) Under Different Turbine Unit Operating Conditions at McNary Dam, 2010. Northwest Fisheries Science Center, National Marine Fisheries Service, Seattle, WA.
- Brege, D.A., R.F. Absolon, B.P. Sandford, and D.B. Dey. 1998. Studies to evaluate the effectiveness of vertical barrier screens and outlet flow control devices at McNary Dam, 1997. National Marine Fisheries Service, Seattle, WA.
- Carlson, T.J. and J.P. Duncan. 2004. Characterization of the McNary Dam Turbine Fish Passage Environment. PNWD-3310. Pacific Northwest National Laboratory, Richland, WA.
- Carlson, T.J., J.P. Duncan, and Z. Deng. March 2008. Data Overview for Sensor Fish Samples Acquired at Ice Harbor, John Day and Bonneville II Dams in 2005, 2006, and 2007. PNNL-17398, Pacific Northwest National Laboratory, Richland, WA.
- Carlson, T.J., Brown R.S., Stephenson, J.R., Gingerich, A.J., Pflugrath, B.D., Colotelo, A.H., Welch, A.E., Benjamin, P.L., Skalski, J.R., Seaburg, A.G., and Townsend, R.L. 2010. Assessment of Barotrauma in Untagged and Tagged Juvenile Chinook Salmon Exposed to Simulated Hydro-Turbine Passage. PNNL-19625. Pacific Northwest National Laboratory, Richland, WA.
- Counihan, T., J. Hardiman, C. Walker, A. Puls, and G. Holmberg. 2006. Survival estimates of migrant juvenile salmonids through Bonneville Dam using radiotelemetry, 2005. Report by the U.S. Geological Survey to the U.S. Army Corps of Engineers, Portland, OR.
- Coutant, C.C. and R.R. Whitney. 2000. Fish behavior in relation to passage through hydropower turbines: A Review. Transactions of the American Fisheries Society 129:351-380.

- Gessel, M.H., D.A. Brege, B.P. Sandford, and G.M. Matthews. 2006. Effects of Turbine Operations and a Prototype Rotating Vertical Barrier Screen on Fish Conditions at McNary Dam, 2005. National Marine Fisheries Service, Seattle, WA.
- Gessel, M.H., D.A. Brege, B.P. Sandford, and G.M. Matthews. 2007. Effects of Turbine Operation and a Prototype Rotating Vertical Barrier Screen on Fish Condition at McNary Dam, 2006. National Marine Fisheries Service, Seattle, WA.
- HDC (Hydroelectric Design Center). 2005. Comparison of Water Passages for Columbia and Snake River Turbines. Northwestern Division, Portland, OR.
- Hockersmith, E.E., G.A. Axel, D.A. Ogden, B.J. Burke, K.E. Frick, B.P. Sandford, and R.F. Absolon. 2008a. Passage Behavior and Survival for Radio-Tagged Subyearling Chinook Salmon and Juvenile Steelhead at Lower Monumental Dam, 2006. National Marine Fisheries Service, Seattle, Washington.
- Hockersmith, E.E., G.A. Axel, D.A. Ogden, B.J. Burke, K.E. Frick, B.P. Sandford, and R.F. Absolon. 2008b. Passage Behavior and Survival for Radio-Tagged Subyearling Chinook Salmon and Juvenile Steelhead at Lower Monumental Dam, 2007. National Marine Fisheries Service, Seattle, Washington.
- Hockersmith, E.E., G.A. Axel, R.F. Absolon, B.J. Burke, K.E. Frick, J.J. Lamb, M.G. Nesbit, N.D. Dumdei, and B.P. Sandford. 2010. Passage Behavior and Survival for Radio-Tagged Subyearling Chinook Salmon and Juvenile Steelhead at Lower Monumental Dam, 2009. National Marine Fisheries Service, Seattle, Washington.
- Kiel, J.D. and Ebner, L.L. 2011. Computation Analysis of Fish Survival at John Day Powerhouse. *In* EPRI-DOE Conference on Environmentally Enhance Turbines, May 19-20, 2011, Washington D.C. Electric Power Research Institute, Palo Alto, CA.
- Neitzel, D.A., R.A. Moursund, M.C. Richmond, C.S. Abernethy, D.D. Dauble, G.R. Guensch, R.P. Mueller, and G.F. Cada. 2000. Laboratory Studies on the Effects of Shear on Fish, Final Report. PNNL-13323. Pacific Northwest National Laboratory, Richland, WA and Oak Ridge National Laboratory, Oak Ridge, TN.
- NOAA (National Oceanic and Atmospheric Administration) Fisheries. 2000. Endangered Species Act – Section 7 Consultation, Biological Opinion. Reinitiation of consultation on operation of the federal Columbia River power system, including the juvenile fish transportation program, and 19 Bureau of Reclamation projects in the Columbia Basin. Northwest Region, Seattle WA.
- NOAA Fisheries. 2004. Endangered Species Act – Section 7 Consultation Biological Opinion. Consultation on remand for operation of the Columbia River power system and 19 Bureau of Reclamation projects in the Columbia Basin [revised and reissued pursuant to court order, NWF v. NMFS, Civ. No. CV 01-640-RE (D. Oregon)]. Northwest Region, Seattle WA.
- NOAA Fisheries. 2008. Biological opinion –consultation on remand for operation of the Federal Columbia River Power System, 11 Bureau of Reclamation Projects in the Columbia Basin and ESA Section 10(a)(1)(A) Permit for Juvenile Fish Transportation Program. National Marine Fisheries Service (NOAA Fisheries) - Northwest Region. Seattle, Washington.
- Normandeau Associates. 2000. Direct survival and condition of juvenile Chinook salmon passed through an existing and new minimum gap runner turbines at Bonneville Dam First Powerhouse, Columbia

River. Prepared by Normandeau Associates, Inc., Drumore, PA; John R. Skalski, University of Washington, Seattle; and Mid Columbia Consulting, Inc., East Wenatchee, WA for the U.S. Army Corps of Engineers, Portland District, Portland, OR.

Normandeau Associates. March 2003. Survival/Condition of Chinook Salmon Smolts under Different Turbine Operations at McNary Dam, Columbia River. Prepared for the U.S. Army Corps of Engineers, Portland District, Portland, OR.

Normandeau Associates. May 2007. Survival/Condition of Chinook Salmon Smolts at Different Turbine Operations at John Day Dam, Columbia River. Prepared for the U.S. Army Corps of Engineers, Portland District, Portland, OR.

Normandeau Associates. 2008. Turbine Operational Effects on Survival/Condition of Yearling Chinook Salmon at Ice Harbor Dam, March 2007. Prepared for the U.S. Army Corps of Engineers, Walla Walla District, Walla Walla, WA.

Pflugrath, B.D., R.S. Brown, and T.J. Carlson. 2012. Maximum neutral buoyancy depth of juvenile Chinook salmon: implications for survival during hydroturbine passage. *Transactions of the American Fisheries Society* 141(2): 520-525.

Perry, R.W., S.D. Fielding, A.D. Cochran, J.L. Schei, J.M. Sprando, G.T. George, N.S. Adams, and D.W. Rondorf. 2004. Turbine Survival and Migration Behavior of Subyearling Chinook Salmon at McNary Dam, 2003. US Geological Survey, Cook, Washington.

Perry, R.W., A.C. Braatz, S.D. Fielding, J.N. Lucchesi, J.M. Plumb, N.S. Adams, and D.W. Rondorf. 2006. Survival and Migration Behavior of Juvenile Salmonids at McNary Dam, 2004. US Geological Survey, Cook, Washington.

Ploskey, G.R., M.A. Weiland, and T.J. Carlson. 2012. Summary of route-specific passage proportions and survival rates for fish passing through John Day Dam, The Dalles Dam, and Bonneville Dam in 2010 and 2011. Interim Report PNNL-21442 of the Pacific Northwest National Laboratory, Richland, Washington.

Politano, M. 2012. Computational Fluid Dynamics (CFD) Modeling to Support the Reduction of Fish Passage Exposure to Predator Habitat at McNary Dam. University of Iowa Hydroscience and Engineering, Iowa City, IA.

Skalski, J.R., D. Mathur, and P.G. Heisey. 2002. Effects of turbine operating efficiency on smolt passage survival. *North American Journal of Fisheries Management* 22:1193-1200.

Skalski, J.R. 2009. Statistical Design for the Lower Columbia River Acoustic-tag Investigations of Dam Passage Survival and Associated Metrics. Report to U.S. Army Corps of Engineers, Portland, OR.

Skalski, J.R., R.L. Townsend, A.G. Seaburg, G.A. McMichael, E.W. Oldenburg, R.A. Harnish, K.D. Ham, A.H. Colotelo, K.A. Deters, and A.Z.D. Deng. 2013a. BiOp performance standard testing: passage and survival of subyearling chinook salmon and juvenile steelhead at Little Goose Dam, 2012. Report PNNL-22140 of the Pacific Northwest National Laboratory, Richland, Washington.

USACE (U.S. Army Corps of Engineers). 2004. Turbine Survival Program (TSP) Phase I Report 1997-2003. Columbia River Basin, Oregon-Washington. Portland and Walla Walla Districts, Hydroelectric Design Center, and Engineer Research and Development Center, Waterways Experiment Station.

Wittinger, R.J., R. Sollars, and C. Hsieh. 2010. Columbia and Snake River Turbines Stay Vane and Wicket Gate Geometry Study. Report by the U.S. Army Corps of Engineers Hydroelectric Design Center, Northwestern Division, Portland, OR.